



DELTA WEDGE

SKILL LEVEL 3 - Recommended for Craftsman Rocketeers.



A DAMON COMPANY

ESTES INDUSTRIES
PENROSE, CO 81240 USA

BEFORE YOU START

Read each step and study the accompanying drawings before doing any of the work called for in that step. Make sure you have all parts and materials. Check off each step as you complete it. Always test-fit parts together before applying glue. It will sometimes be necessary to sand edges of rings, tubes, etc. to obtain proper fit. If you are in doubt about the relative size or location of some parts, refer back to this exploded view drawing for clarification. Adequate glue joints are very important for a flying model rocket. Follow the instructions carefully in this respect.

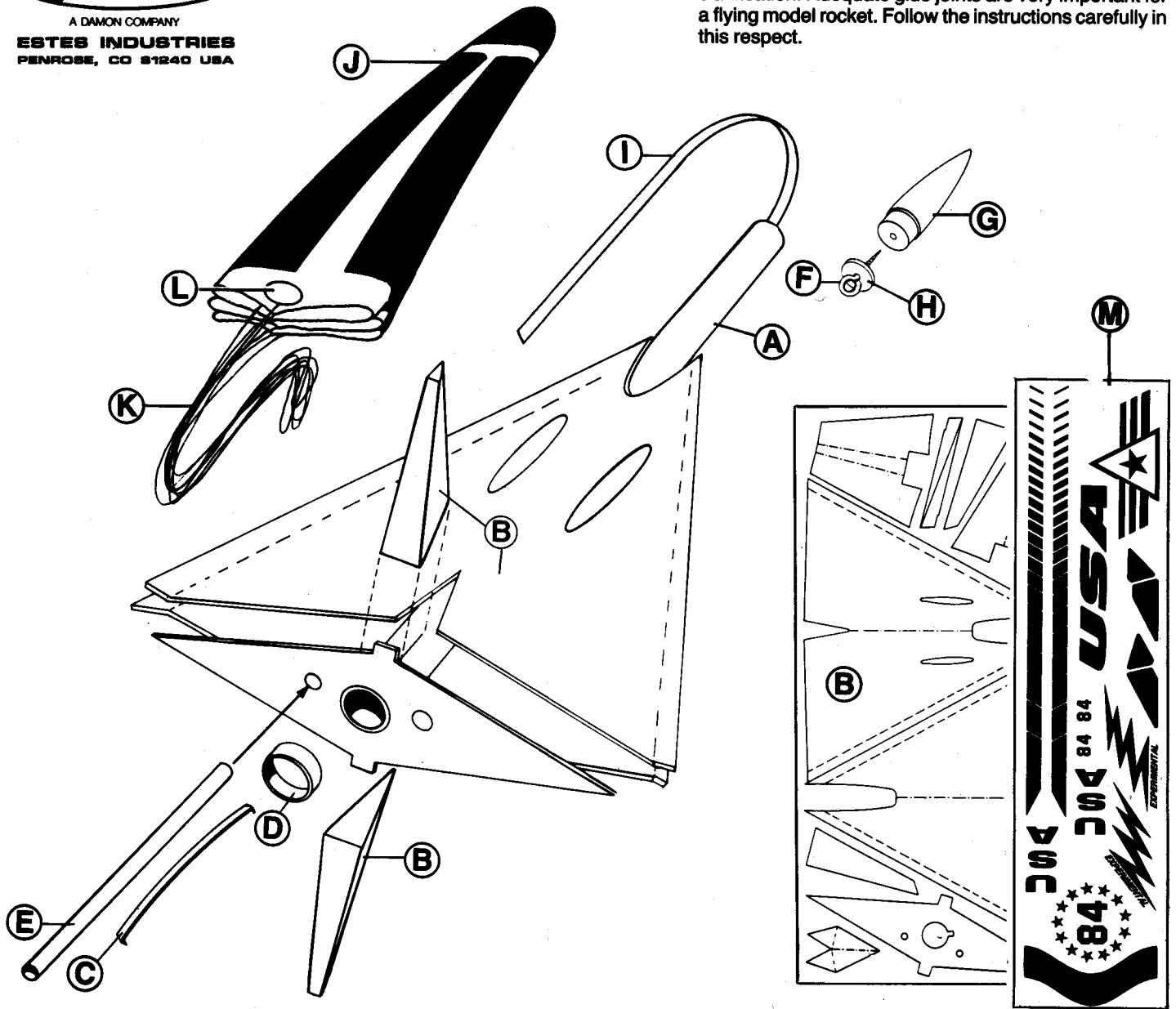

RECOMMENDED ENGINES:
A8-3, B4-4, B6-4, B8-5, and C6-5
First Flight A8-3

TOOLS AND MATERIALS

In addition to the parts included in this kit you will need: Scissors, pencil, ruler, fine or extra-fine grit sandpaper, sanding sealer, a medium-size modeling paint brush, masking tape, modeling knife with sharp blade, medium-dark blue enamel spray paint, and household white glue or resin glue (Elmer's, Titebond, or similar). Other types of glue are not recommended.

PARTS LIST

KIT NO. 1931

A	1	Body Tube (type BT-20P) 13-3/4" Long	30333
B	1	Die-Cut Card (type RA-1931)	32457
C	1	Engine Hook (type EH-2)	35025
D	1	Retainer Ring (type HR-20)	30168
E	2	Launch Lugs (type LL-2C)	38180
F	1	Screw Eye (type SE-2A)	38252
G	1	Nose Cone (type BNC-20AZ)	70228
H	1	Lead Weight (type NCW-1A)	38280
I	1	Shock Cord (type SC-1)	85730
J	1	Parachute (type PK-12A)	85564
K	1	Shroud Line (type SLT-72)	38237
L	1	Tape Discs (type TD-3F)	38406
M	1	Decal (type KD-1931)	37246

INCHES 1
2
3
4
5
6
7
8
9
10

ASSEMBLY INSTRUCTIONS

1

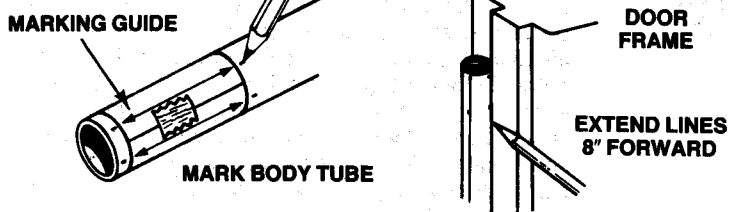

Cut the body tube marking guide from page 6 of these instructions. Wrap the guide around one end of the body tube (part A) and tape the ends together. Mark the body tube at each of the arrow points. Remove the guide. Using the inside edge of a door frame as a guide, draw lines at the marks. Extend the lines 8" from the end of the tube.

2

DIE-CUT CARD COMPONENTS

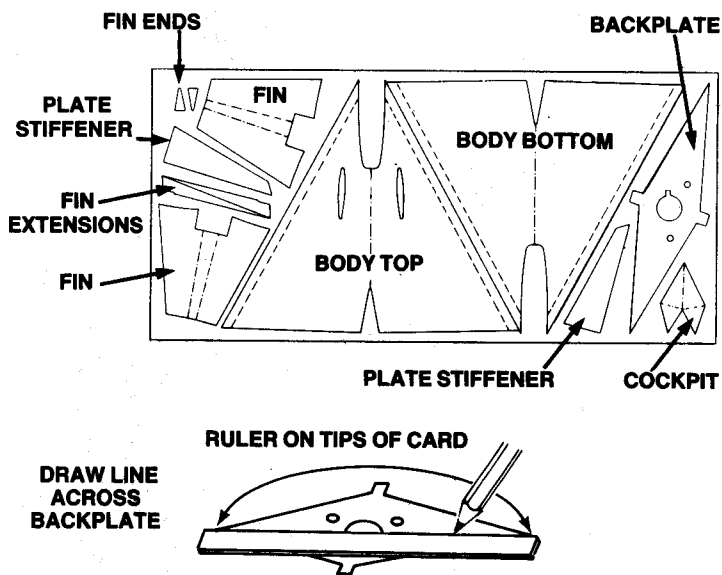

Free the parts from the die-cut card (part B) by running a knife blade along the die-cut lines. *Do not punch the parts from the card.* Sort and identify the parts. Turn the backplate over so the dull side is up. Lay a ruler across the part and line it up exactly on the tips of the card. Draw a pencil line across the part.

3

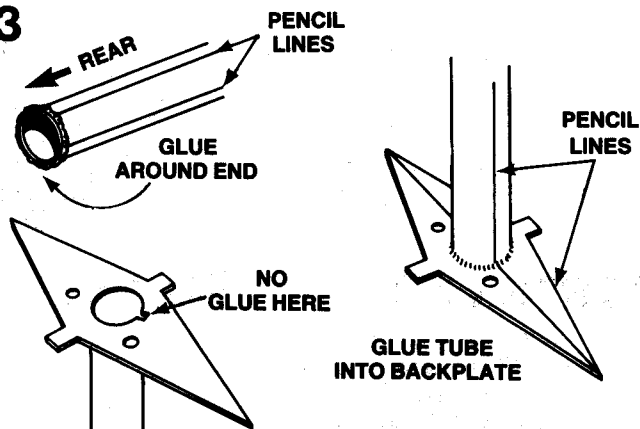

Cut out a section from the plastic kit bag and lay on your work surface. Lay the backplate, pencil line side up, on the plastic. Apply a light bead of glue to the rear of the body tube. Holding the backplate flat on the table, insert the end of the tube into the hole. Twist the tube until 2 of the pencil lines are lined up with the line drawn across the backplate. Hold the parts until the glue begins to set. Lift the assembly from the plastic. Using a knife blade, remove any glue from the body tube in the area of the rectangular opening. Let the glue dry, then apply a light bead of glue around the joint for added strength.

2 4

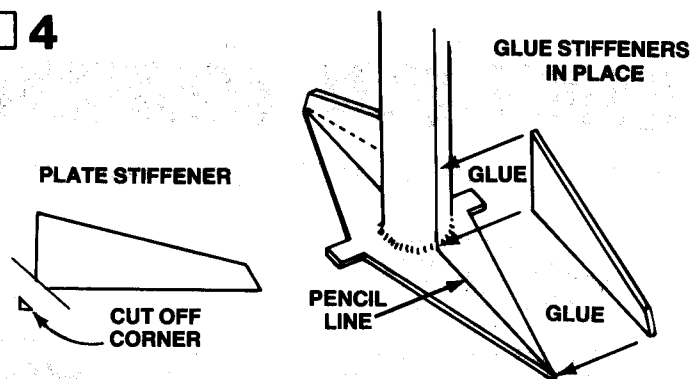

Cut off a very small amount of material from the bottom corners of the plate stiffeners. This will allow clearance for the glue fillet on the backplate-body tube joint. Apply a bead of glue to the bottom and rear edges of the stiffeners and glue them in place as shown. After the glue is dry, apply a second bead of glue to the joints.

5

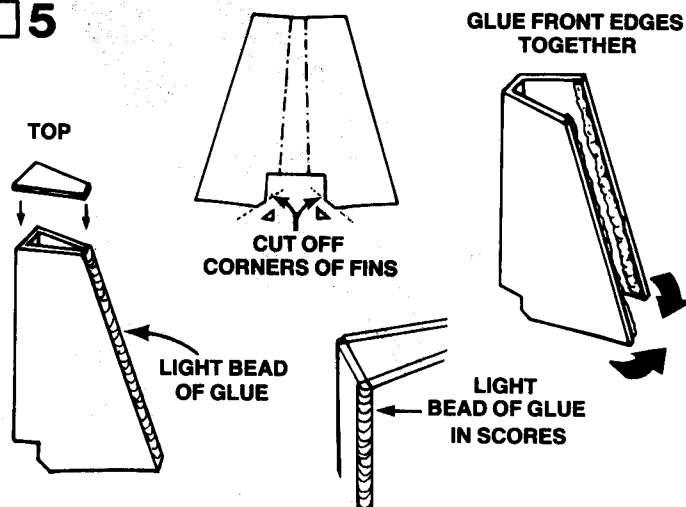

Cut off the tips of the bottom corners of the fins. "Pre-fold" a fin by folding all the way over at one score line, unfolding, and then folding all the way over at the other score line. Apply a bead of glue to the inside front edge of one side and press against the other front edge. Make sure the edges are even. Hold until glue begins to dry. Apply a bead of glue to the top edges of the fin and attach the fin top. Fill the scored corners with a light bead of glue. Wipe away excess glue. Apply a light bead of glue to the front edge to smooth over the joint. Construct the second fin in the same manner. Allow glue to dry completely.

6

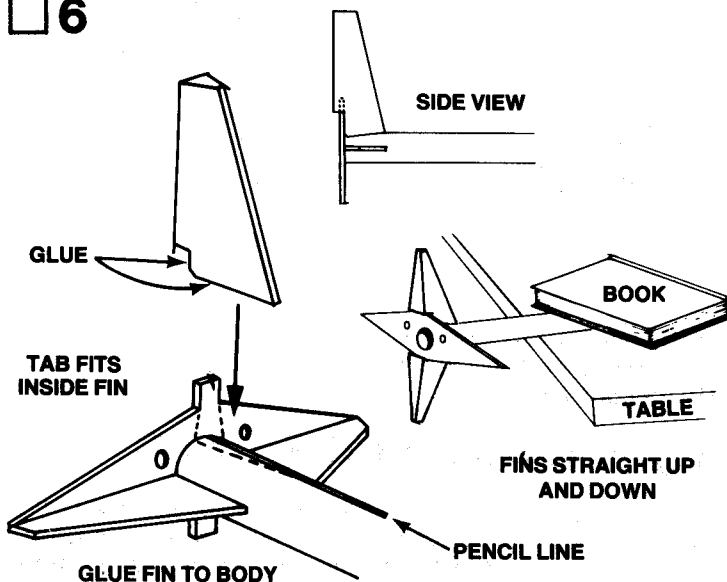

Test fit the fins onto the body. The tabs on the backplate fit up inside the fins and key them into proper alignment. The fronts of the fins are

centered on the pencil lines. Apply glue to the bottom and lower rear edges of a fin and glue it to the body as shown. Hold in place until the glue begins to set. Glue the second fin to the other side of the body. Make sure the fins extend straight up and down from the body. Support as shown until glue dries. Apply a second bead of glue to the fin-body joints and let dry.

7

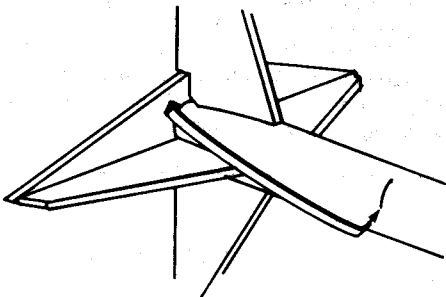
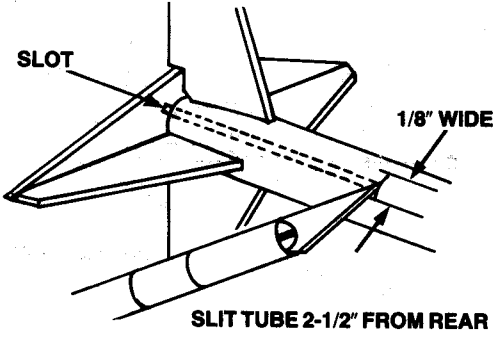

INSERT END OF ENGINE HOOK IN SLIT

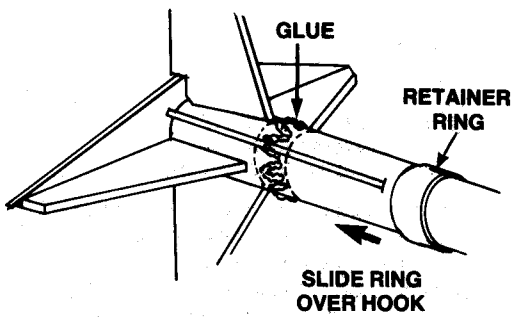

SLIDE RING OVER HOOK

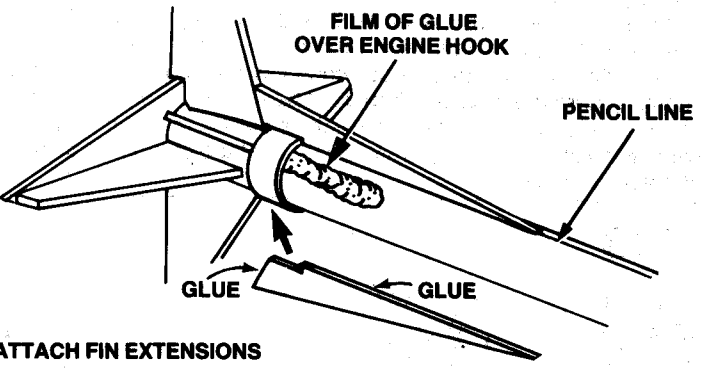

ATTACH FIN EXTENSIONS

Rotate the model so the slot in the backplate is pointing toward you. Measure 2-1/2" forward from the slot and mark the body tube. At the mark, and directly in line with the slot, cut a 1/8" wide slit in the tube. Insert one end of the engine hook (part C) through the slot and push the other end into the slit in the tube. Apply a bead of glue around the body tube 1/2" forward of the fins. Slide the retainer ring (part D) onto the front of the body tube. Slide the ring back over the hook and against the fins. Smear a film of glue over the forward portion of the engine hook. Glue the fin extensions in place as shown. Make sure they are centered on the pencil lines.

8

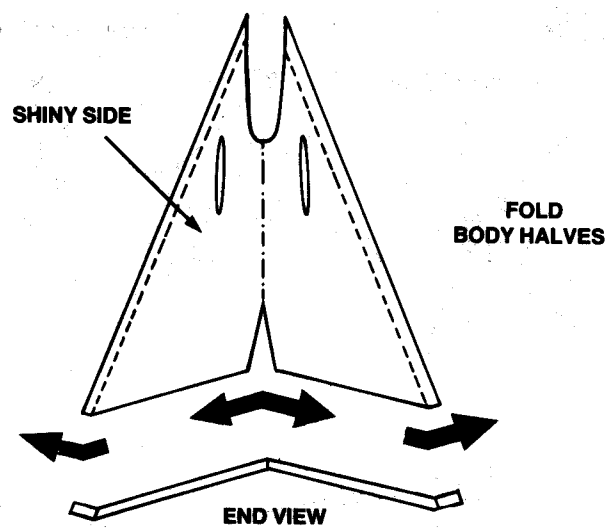

APPLY GLUE TO ONE SIDE

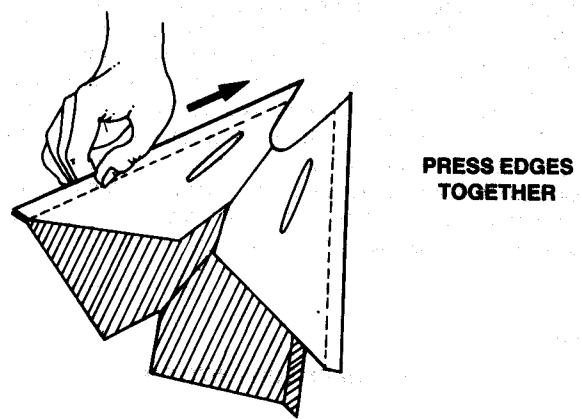
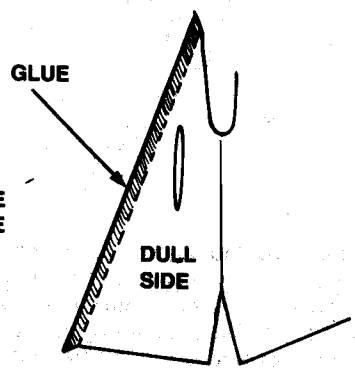

PRESS EDGES TOGETHER

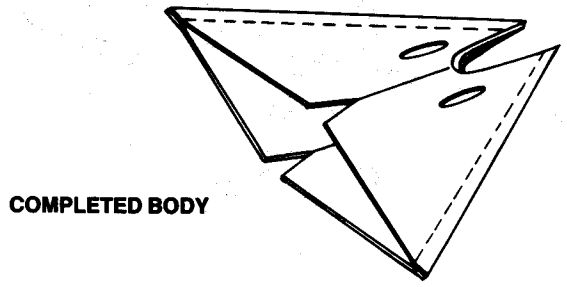

COMPLETED BODY

Locate the two die-cut body halves. Place the parts on the table with the shiny sides up. Fold along the score lines as shown. Do not fold more than is shown in the drawing. Apply glue to one edge of one half as shown. Lay the other half on top and align the edges exactly. Pull the seam between your thumb and forefinger. Make sure the edges stay in firm contact. Hold the parts together until the glue begins to dry. Glue the other side of the body together in the same manner. Allow glue to dry before proceeding.

9

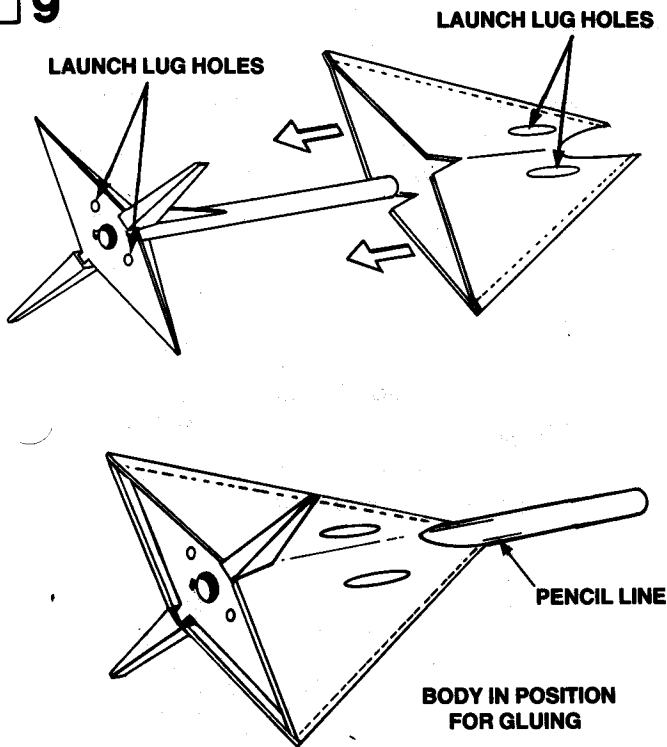

Slide the body into position as shown. Make sure that the launch lug openings in the backplate and body are on the same side. The rear edge of the body is even with the rear of the fins. Check your model to see that it looks like the drawing. Use a toothpick or small stick to apply a light bead of glue all around the joint between the backplate and the inside rear of the body. Hold the body against the backplate until the glue dries. Line up the front edges of the body with the pencil lines and apply a small amount of glue to the front of these joints. Let this glue dry, then apply glue all around the body-body tube joints. Smooth the glue with your finger and wipe away excess. Apply a bead of glue to the fin-body joints. Again, smooth out and remove excess glue with your finger. After the glue has dried, re-check all joints. Apply more glue to any areas where there are voids. Immediately smooth the glue with your finger. The area where the front of the body joins the tube may require several glue applications to provide a smooth, even transition.

10

GLUE LAUNCH LUGS INTO BODY

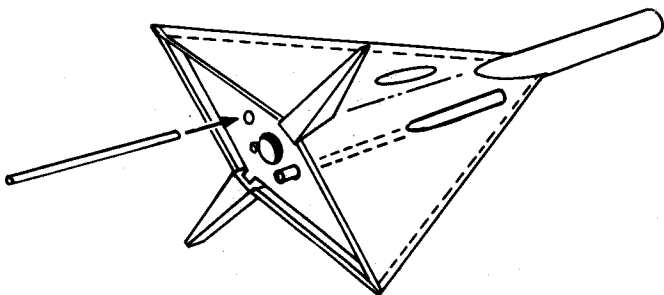

Insert one of the launch lugs (part E) into a hole in the backplate. Push the launch lug forward until it exits the opening in the forward portion of the body. Continue pushing until the rear of the lug is even with the rear of the body (sticking out of backplate about 1/4"). Using a toothpick, apply a small bead of glue around the launch lug-backplate joint. Let the glue dry, then apply glue around the launch lug where it extends from the body. Smooth the glue with your finger. Repeat the process with the remaining launch lug.

4 11

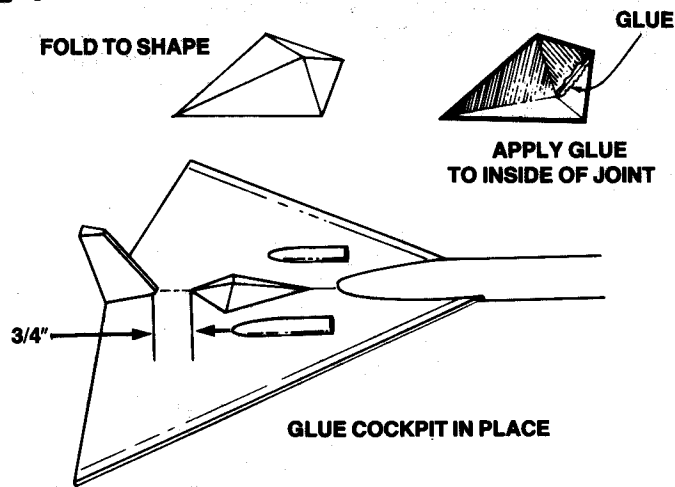

Fold the cockpit into shape and apply glue to the inside edge where it is joined. Hold the cockpit together until the glue dries. Mark the top of the body (the side with the launch lugs) 3/4" forward of the fin. Apply a bead of glue to the bottom edges of the cockpit. Set in place as shown and hold until glue dries. Apply glue around the joint and smooth with your finger. Using a toothpick, apply a very small bead of glue in the score lines on the cockpit.

12

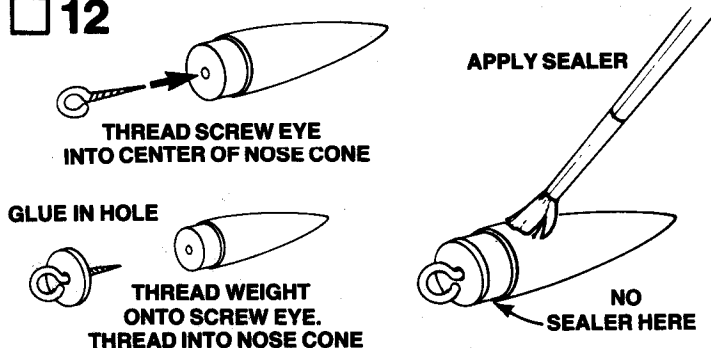

Thread the screw eye (part F) into the exact center of the nose cone (part G). Remove the screw eye and thread the lead weight (part H) onto the screw eye. The weight should be positioned all the way back against the loop of the screw eye. Squirt glue into the hole in the nose cone and thread the screw eye - weight assembly into place. Apply sanding sealer to the nose cone (except shoulder). Let the sealer dry and sand with fine sandpaper. Repeat the sealing and sanding process until the balsa grain is filled and the surface looks and feels smooth. Check the fit of the nose cone into the body tube. The cone should separate easily, but should not be so loose it will fall out when turned upside down. If the fit is too tight, sand the shoulder of the nose cone. If the fit is too loose, wrap cellophane tape around the shoulder of the nose cone.

13

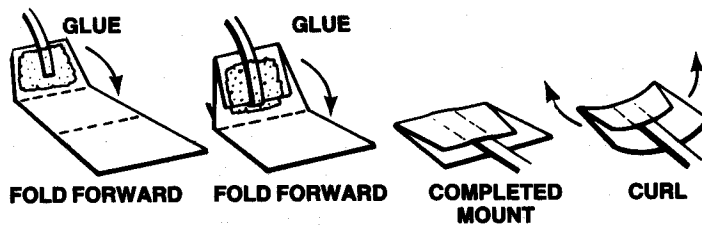

Cut out the shock cord mount from page 6 of the instruction sheet. Fold on dotted lines, then unfold and apply glue to Section 1. Lay the end of the shock cord (part I) into the glue. Fold over and apply glue to the back of Section 1 and the exposed portion of Section 2. Fold again to complete mount. Curl the edges of the mount up so it will match the contour of the body tube and hold with your fingers until the glue sets.

14
SET BACK TO ALLOW FOR NOSE CONE

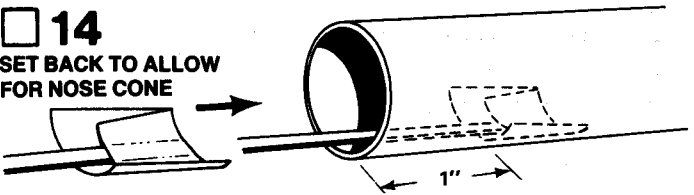

Use a finger or stick to apply glue to the inside of the front of the body tube 1" to 2" from the front of the tube. Press the shock cord mount firmly into position in glue far enough from the front edge of the tube to allow clearance for the nose cone to fit into place. To insure a good bond use a stick or your finger to smear a film of glue over the mount and surrounding area in the body tube.

15
TAPES DISC
PRESS DOWN FIRMLY

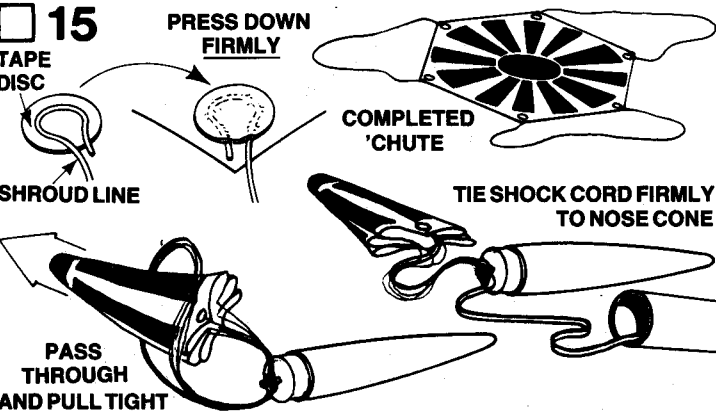

Cut out the parachute (part J) on its edge lines. Cut three equal lengths of shroud line (part K). Attach line ends to the top of the parachute with tape discs (part L) as shown. Form a small loop in the end of a shroud

line. Holding loop, gently center loop inside tape disc on the sticky side. Then carefully press tape disc onto its proper place on the top of the parachute. Firmly press the tape disc into place until both tape disc and parachute material are molded around the shroud line loop. Repeat for other shroud line ends and tape discs. Pass the shroud line loops through the screw eye on the nose cone. Pass the parachute through the loop ends and pull the lines tight against the screw eye. Tie the free end of the shock cord firmly to the nose cone screw eye. A square knot or strong double knot should be used. Pack 'chute and shock cord into body and socket nose cone in place.

16

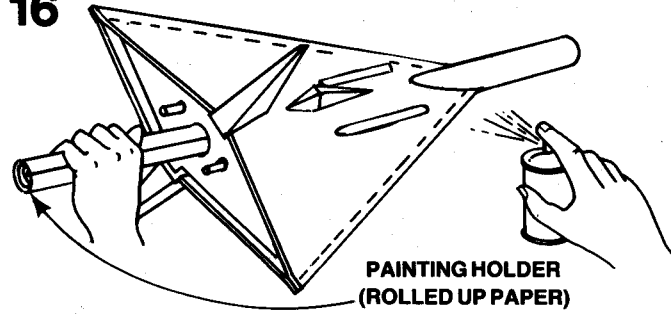

Before painting, lightly sand all glue joints with fine sandpaper. Do not sand hard enough to sand away the surface of the cardstock. Check all glue joints for any holes or dips in the glue. Fill these with glue, smooth out and let dry. Wipe the model with a clean cloth to remove any sanding dust. Make a painting holder by rolling a piece of paper tightly and inserting it into the body tube. We recommend a medium-dark blue spray paint. For best results, follow directions printed on the spray can. After the model is painted, wait at least 3 hours before applying decals.

DECAL PLACEMENT

17

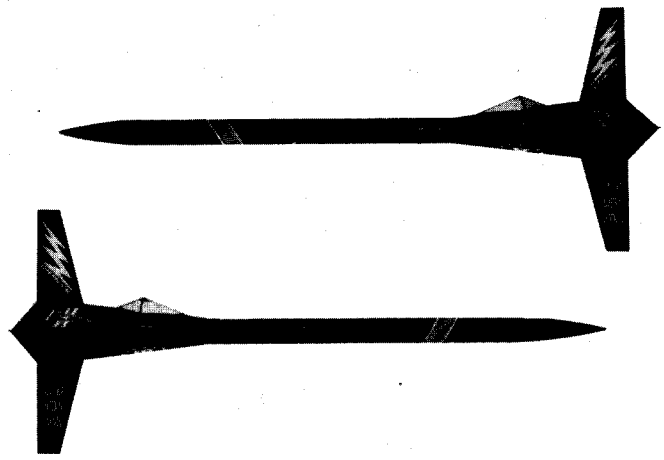
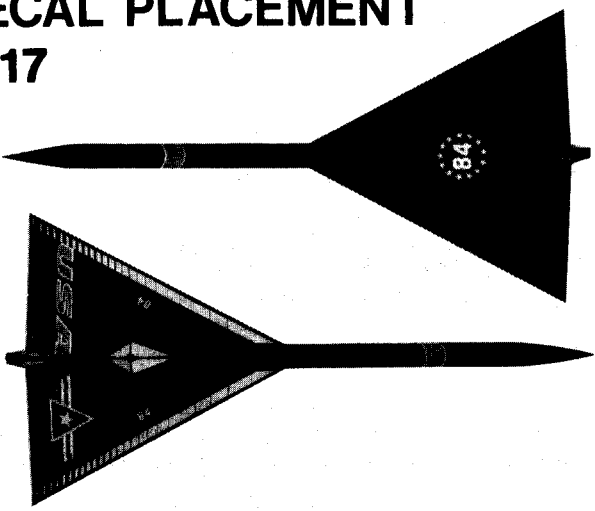

(A) Cut only one decal at a time from decal sheet (part M). (B) Submerge decal in lukewarm water until decal slides on backing paper (usually 15 to 30 seconds). (C) Gently slide decal from backing paper onto model. (D) Move decal into exact position and carefully blot away excess water with a soft cloth. (E) If the decal "sticks" before you have it in position, apply water over the decal with a brush. This will permit the decal to be moved. (F) Smooth out all wrinkles and air bubbles before the decal dries.

Apply the decals in the positions shown. In the case of the cockpit decals, trim away the clear material almost to the windows. Otherwise, the clear would stick out beyond the edges of the cockpit. Apply the front body band so the edges meet and overlap at the bottom of the body tube. When the decals are dry, wipe the model with a damp cloth to remove any water spots.



A DAMON COMPANY

ESTES INDUSTRIES
PENROSE, CO 81240 USA

LAUNCHING COMPONENTS

- To launch your rocket you will need the following items:
- An Estes model rocket launching system
 - Flame resistant recovery wadding (Estes Cat. No. 2274)
 - Estes A8-3, B4-4, B6-4, B8-5, and C6-5 model rocket engines.
- Use an A8-3 engine for your first flight.

Be sure to follow the HIAA-NAR* Model Rocket Safety Code when carrying out your model rocket activities.

*HIAA—Hobby Industry of America

*NAR—National Association of Rocketry

COUNTDOWN CHECKLIST

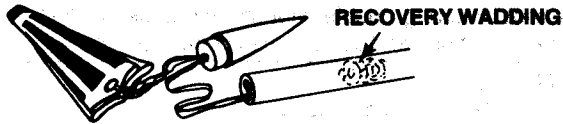

RECOVERY WADDING

Pack 2 or 3 squares of loosely crumpled recovery wadding into the body tube. Usually this will fill the body tube for a distance equal to about 1-1/2 times its diameter.

T-12

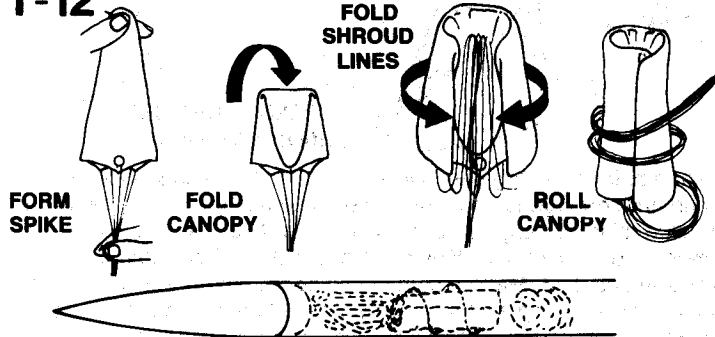

Hold the parachute at its center and pass the other hand down it to form a "spike" shape. Fold this spike in half. Fold shroud lines back along parachute and then back down to lower edge of parachute to reduce length of shroud line "left over". Roll parachute into tube shape to fit easily into body. Any remaining shroud line should be loosely wrapped around parachute. Pack 'chute into the body tube on top of the wadding. Pack the shroud lines and shock cord in on top of the parachute and slip the nose cone into place.

NOTE: DO NOT pack parachute until you are actually ready to launch. For maximum parachute reliability, lightly dust the 'chute with ordinary talcum powder before each flight, especially in cold weather.

T-11

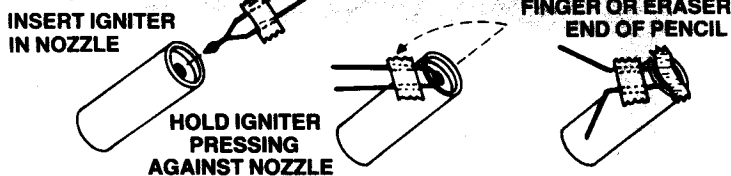

Select an engine and install an igniter as directed in the engine instructions. The engines recommended for use with this rocket are the A8-3, B4-4, B6-4, B8-5 and C6-5 made by Estes. Use an A8-3 for your first flight.

T-10

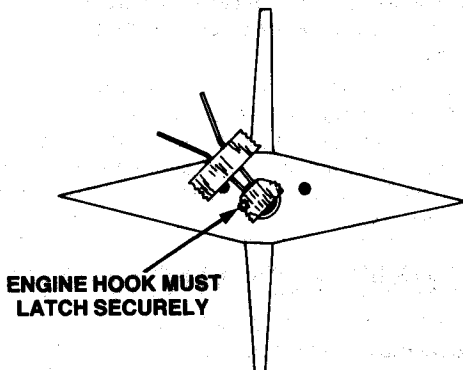

ENGINE HOOK MUST LATCH SECURELY

Insert engine into rocket engine mount. Engine hook must latch securely over end of the engine.

T-9 Disarm the launch panel—REMOVE SAFETY KEY!

T-8 ALTERNATE MASKING TAPE "STAND-OFF"

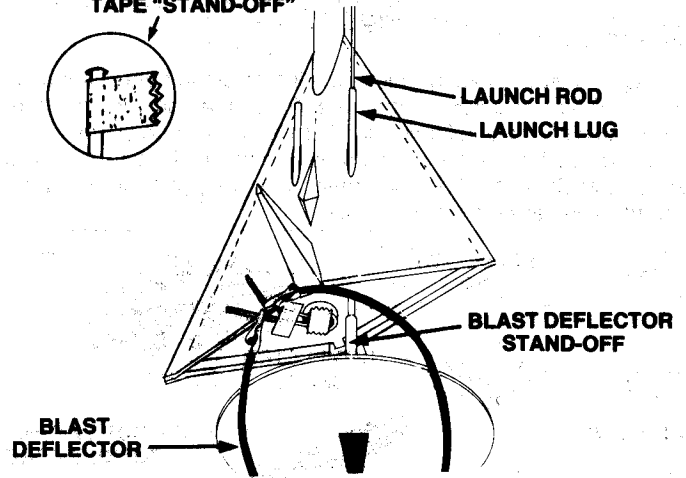

Slide the launch rod through rocket launch lug. Make sure the rocket slides freely on the launch rod. The rocket must be supported by a "stand-off" to keep the igniter wires from touching the metal blast deflector. If your launch system does not have a stand-off, wrap a piece of masking tape around the launch rod to support the rocket. Clean the micro-clips and attach them to the igniter wires. Attach the clips as close to the protective tape on the igniter as possible. Arrange the clips so they do not touch each other or the metal blast deflector.

T-7 Clear the launch area. Alert recovery crew and trackers. Check for low flying aircraft and unauthorized persons in the recovery area.

T-6 Arm the launch panel—INSERT SAFETY KEY!

5-4-3-2-1-LAUNCH!!

Repeat Countdown Checklist for each flight.

MISFIRE PROCEDURE

Disarm the launch panel. Wait one minute before approaching the rocket on the launch pad. Remove the rocket, clean the igniter residue from the nozzle of the engine, and carefully install a new igniter. Repeat the Countdown Checklist.

Failure of the rocket engine to function properly is nearly always caused by a failure to install the igniter correctly. This failure permits the igniter to heat and burn into two pieces without igniting the engine.

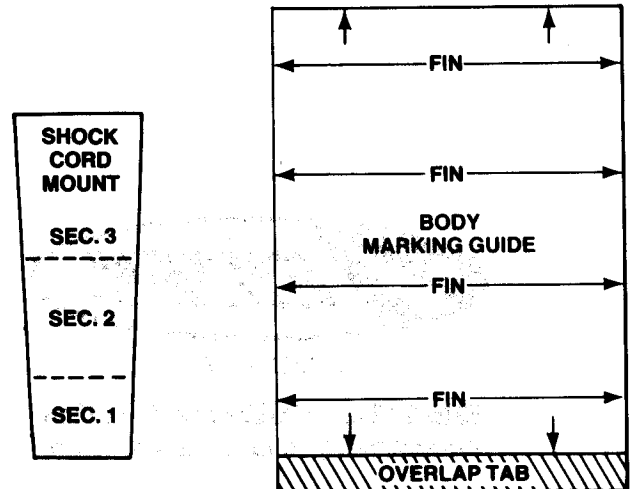

Use Thick Card Stock
Make 2 (one for bottom and top)
Cut out oval holes for TOP pattern only

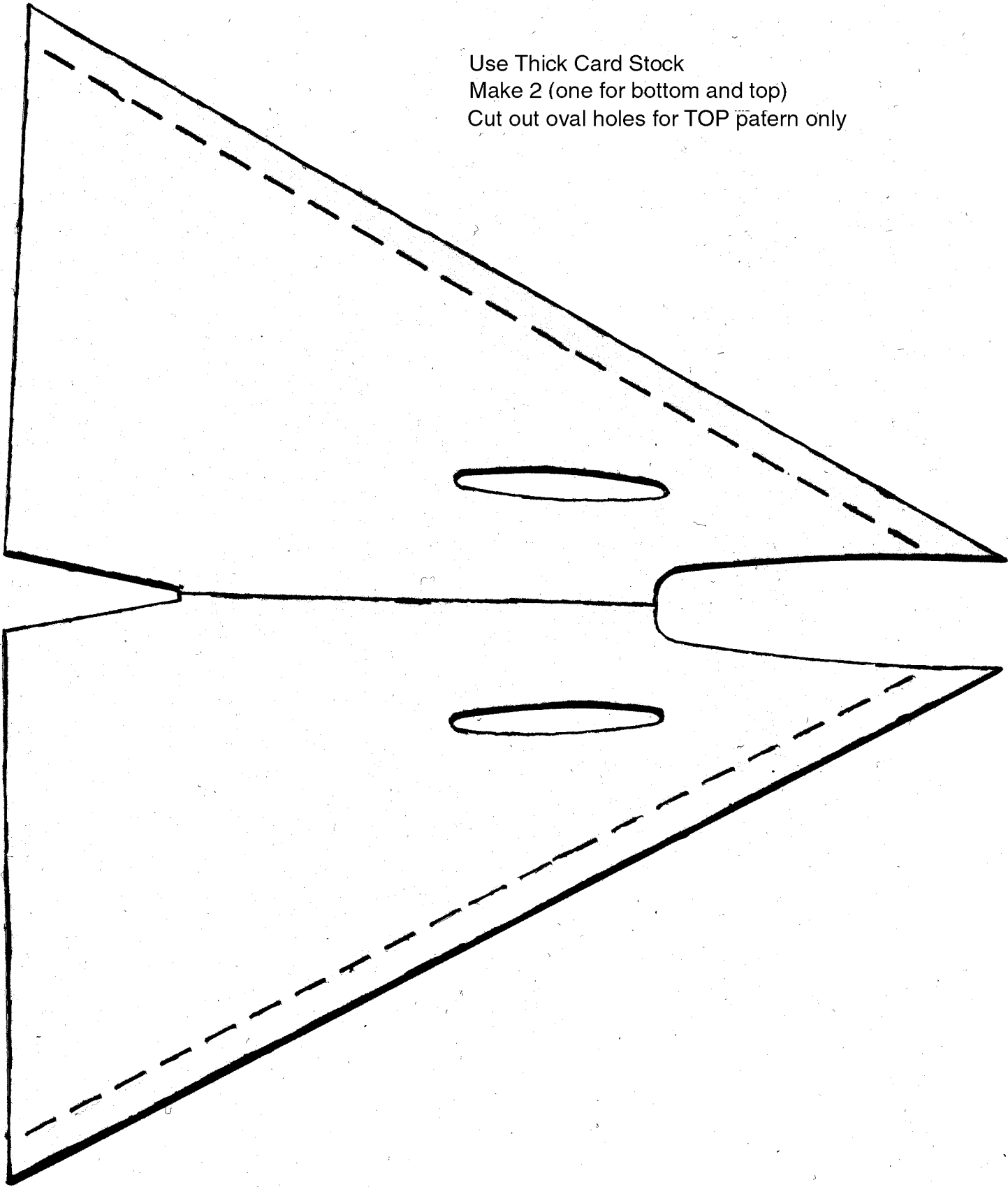

Use Thick Card Stock

Make 2 copies of the top 4 patterns

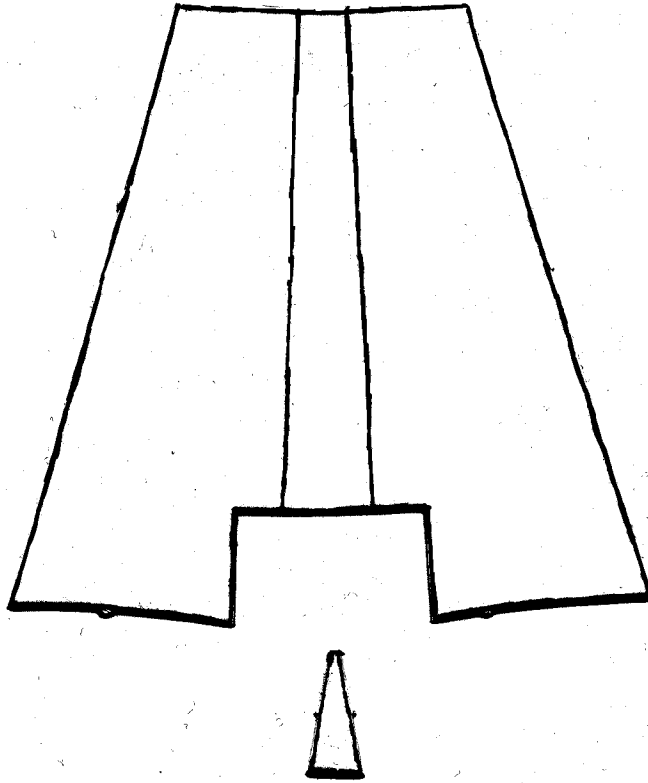

Make 1 Copy of the cockpit and aft panel

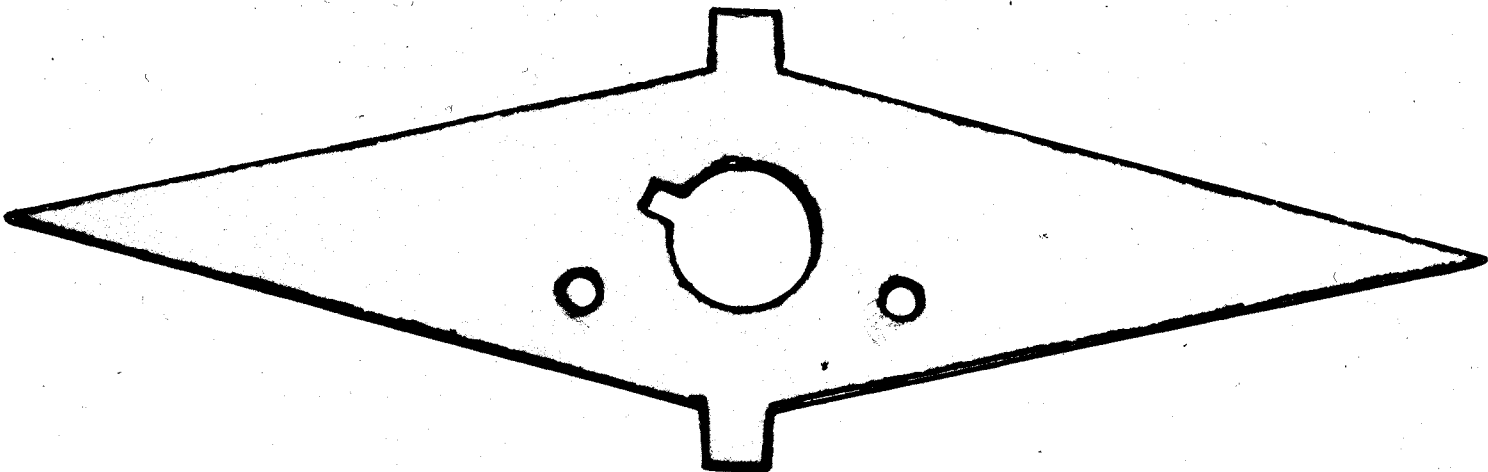
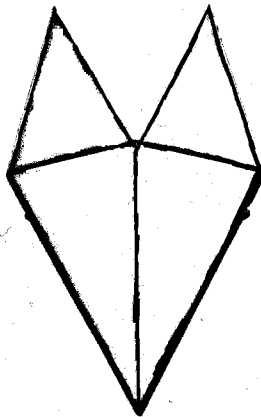

USA

USA

84 84

USA

37246 ESTES
INDUSTRIES

84

EXPERIMENTAL

EXPERIMENTAL



DELTA WEDGE

FLYING MODEL ROCKET

SKILL LEVEL 3

- Unique Wedge Design
- 12" Parachute Recovery
- Large Two-Color Decal
- Die-Cut Parts
- Quick-Release Engine Mount

Length: 18.5 in (46.8 cm)
Dia.: 1.75 in (4.4 cm)
Weight: 1.50 oz (42.5 g)
Engine Types: A6.5 (Max Flight), B4.4, B4.4, B4.5, C4.5

FLIGHTS
UP TO
1000
FEET!

Recommended for ages 10 and over.
This is a hobby product. It is not
intended for use as a toy. It is not
to be used in a way that could cause
injury. Please read the instructions
carefully. Engines, launchers, and
accessories sold separately.



A ZWILLER COMPANY

ESTES INDUSTRIES
PENNSBORO, CO 87040 USA

#1931

