



Galactic Taxi

BEFORE YOU START

SKILL LEVEL 3 RECOMMENDED FOR EXPERIENCED ROCKETEERS

Read each step and study the accompanying drawings before doing any of the work called for in that step. Make sure you have all parts and materials. Check off each step as you complete it. Always test-fit parts together before applying glue. It will sometimes be necessary to sand edges of rings, tubes, etc. to obtain proper fit. If you are in doubt about the relative size or location of some parts, refer back to this exploded view drawing for clarification. Adequate glue joints are very important for a flying model rocket. Follow the instructions carefully in this respect.

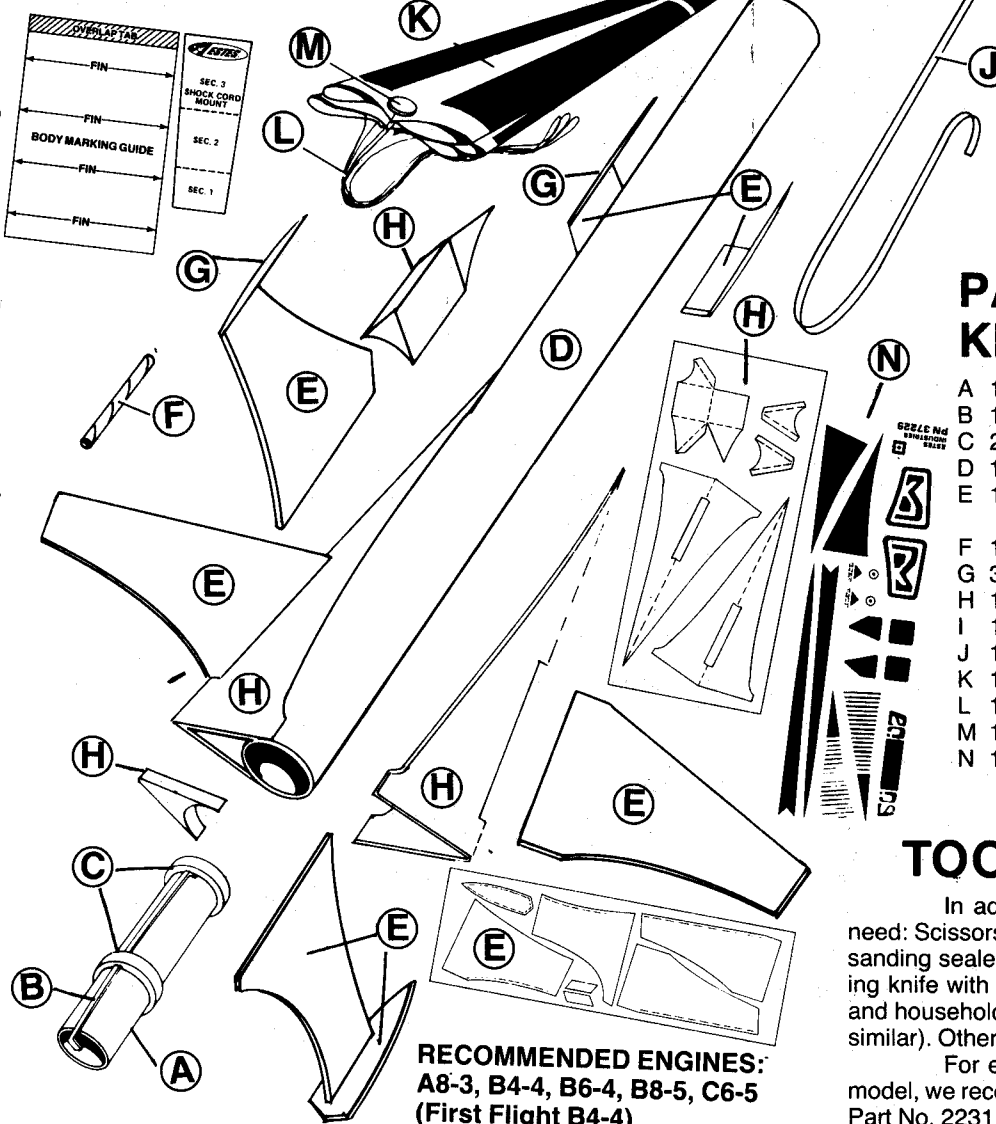

PARTS LIST KIT NO 1914



A	1	Engine Mount Tube (type BT-20J)	30326
B	1	Engine Hook (type EH-2)	35025
C	2	Centering Rings (type AR-2050)	30164
D	1	Body Tube (type BT-50B)	30379
E	1	Balsa Die-Cut Sheet (type BF-1914)	32614
F	1	Launch Lug (type LL-2A)	38175
G	3	Toothpicks	32066
H	1	Die-Cut Card (type RA-1914)	30136
I	1	Nose Cone (type PNC-50KA)	71028
J	1	Shock Cord (type SC-1)	85730
K	1	Parachute (type PK-12A)	85564
L	1	Shroud Line (type SLT-72)	38237
M	1	Tape Discs-6 (type TD-3F)	38406
N	1	Decal (type KD-1914)	37229

TOOLS AND MATERIALS

In addition to the parts included in this kit you will need: Scissors, pencil, ruler, fine or extra-fine grit sandpaper, sanding sealer, a medium-size modeling paint brush, modeling knife with sharp blade, gloss yellow enamel spray paint, and household white glue or resin glue (Elmer's, Titebond, or similar). Other types of glue are not recommended.

For easy and positive alignment of the fins on your model, we recommend the use of Estes' Fin Alignment Guide, Part No. 2231.

RECOMMENDED ENGINES:
A8-3, B4-4, B6-4, B8-5, C6-5
(First Flight B4-4)

ASSEMBLY INSTRUCTIONS

1

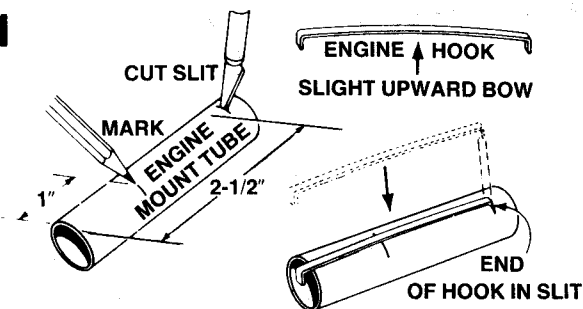

Mark the engine mount tube (part A) at 1" and 2-1/2" from one end. Cut a 1/8" long slit at the 2-1/2" mark. Gently bend the engine hook (part B) so that it bows upward very slightly in the middle. (Study the drawing—Don't bend the wrong way.) Insert one end of the engine hook into the slit in the tube.

2

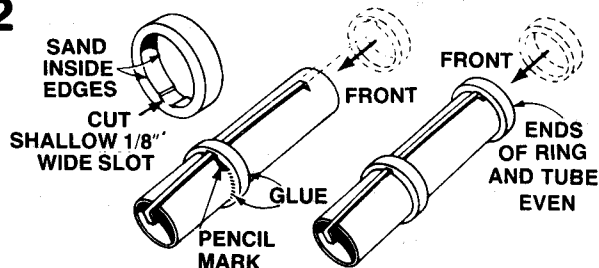

Sand the inside edges of the two centering rings (part C) to remove burrs. The rings should slide easily onto the engine mount tube and slide it down to the 1" mark. Make sure the engine hook runs straight down the tube, then apply glue to both sides of this ring. Apply glue around the front end of the engine mount tube and slide the remaining centering ring into place (front of ring even with the end of the tube.)

3

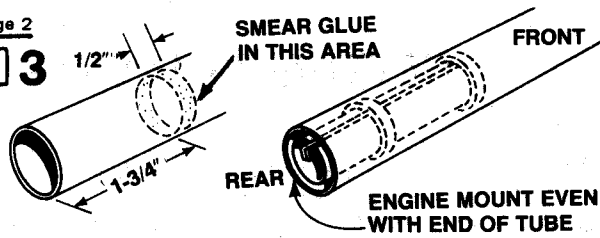

The engine mount unit will be pushed into place so that the rear of the engine mount (end with engine hook projecting) is even with the end of the body tube. Sand the inside edge of the body tube and the centering rings, if necessary, to obtain a good fit. Use a stick to apply a generous bead of glue around the inside of the body tube about 1-3/4" from the end. Making sure the engine hook extends to the rear, slide the engine mount into the body tube until the end of the mount is even with the rear of the body tube. Do not pause or the glue may "lock" with the mount in the wrong position.

4

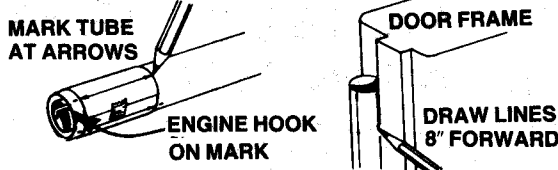

Cut out the tube marking guide from page 5 of these instructions and wrap it around the rear of the body tube. Place the tube marking guide so that the engine hook lines up with a fin placement line (arrow point). Mark the body tube at each of the arrow points. Remove the marking guide. Using a door frame as a guide, draw lines connecting each pair of marks. Extend the lines about 8" forward along the body tube.

5

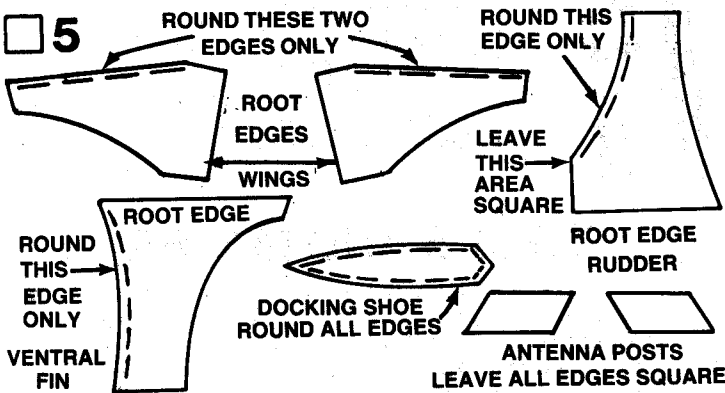

Lightly sand both sides of the balsa die-cut sheet (part E). Free the parts by carefully running a knife along the die-cut lines. Use sandpaper to round only the edges shown. Sand all other edges square. Note: The word "root edge" means the edge of the part that glues to the body tube.

6

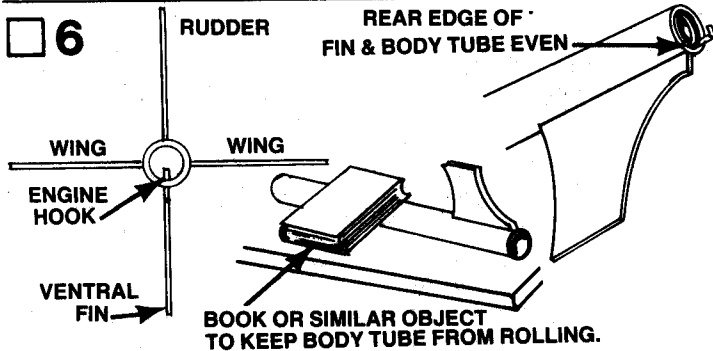

The balsa parts are attached to the body in the positions shown. Attach the ventral fin first. Note that it is aligned with the engine hook. Apply a bead of glue to the root edge of the fin. Hold it for a minute to allow the glue to become tacky, then attach the fin to the body in the position shown. Wipe away any excess glue. Make sure the fin projects straight from the body. Support the body with the fin in an upright position and allow the glue to dry.

7

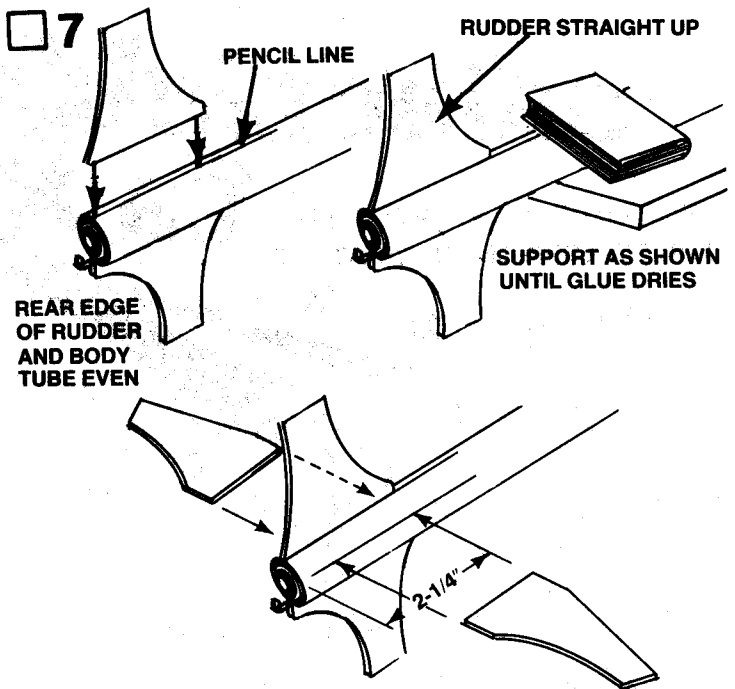

Glue the rudder to the body in the position shown. Make sure the rudder extends straight from the body. Lay the body on a table with the fin and rudder extending off the edge. Make sure the rudder is pointing straight up and weight the front of the body so it won't roll. Allow the glue to dry before proceeding.

Place a mark on each wing line 2-1/4" from the rear of the body. Glue one wing to the body with the wing centered on the pencil line and the front edge of the wing on the 2-1/4" mark. Check the wing alignment and support as previously described until the glue dries. Attach the other wing in the same manner.

8

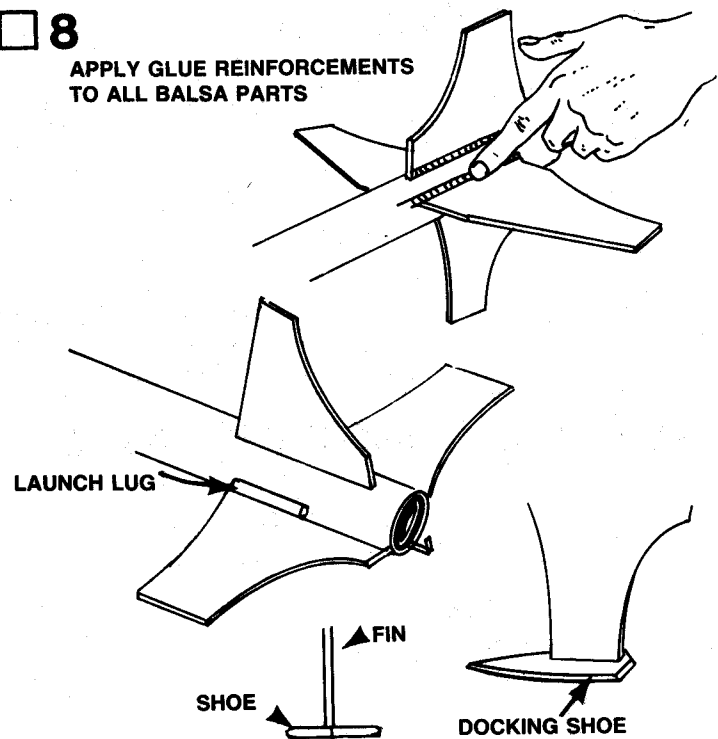

Apply a bead of glue to both sides of the rudder-body tube joint. Pull your finger along each side of the joint to smooth the glue into even reinforcements and to remove excess glue, repeat this procedure with the ventral fin and both wings. Glue the launch lug (part F) to the side of the ventral fin as shown. Glue the docking shoe to the bottom of the ventral fin in the position shown. Use a pointed stick to apply small glue reinforcements at the joints.

9

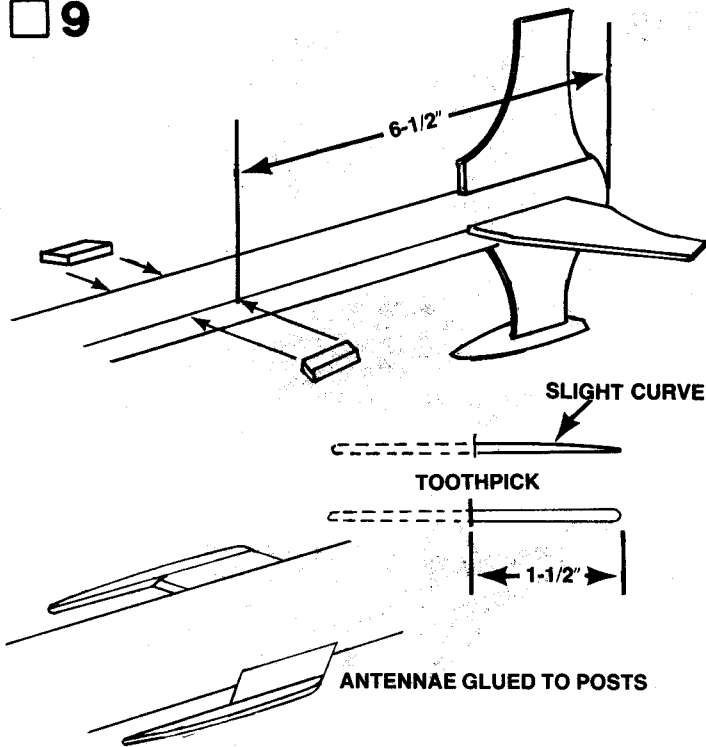

Mark the wing lines 6-1/2" from the rear of the body. Glue the antenna posts in place, centered on the wing lines with the rear edges on the 6-1/2" marks. Cut two of the toothpicks (part G) to 1-1/2" in length as shown. Note that when the toothpicks are turned on edge, one side is straight and one is slightly curved. Glue the straight sides of the toothpicks to the antenna posts and align them straight with the body.

10

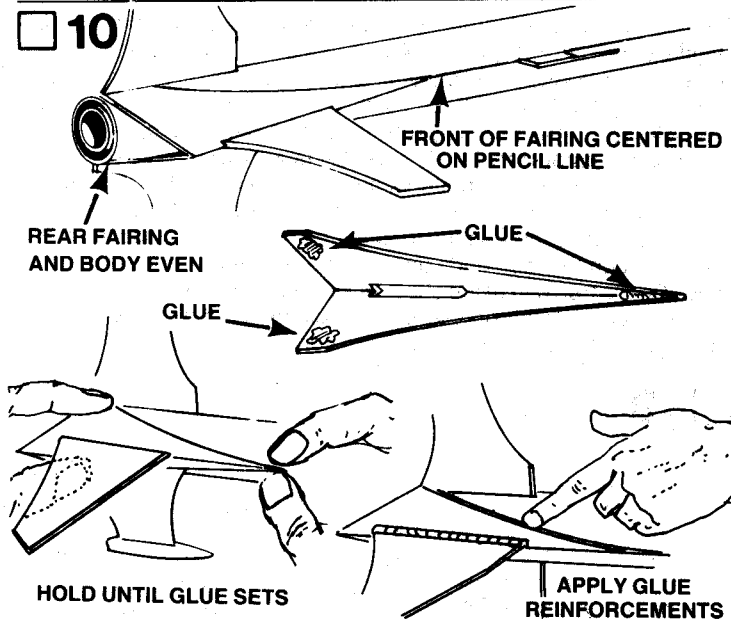

Use a knife to free the parts from the die-cut card (part H). Fold one of the side fairings on the scored line. The fairing slips over the wing and fits against the body as shown. If necessary, trim material from the front or back of the wing slot to achieve a good fit. It is not practical to glue the fairing in place in one operation. Instead, use the following procedure. Apply a small bead of glue to the inside of the rear edges and front of the fairing. Slide the fairing into place and hold with your fingers until the glue sets. Apply a small bead of glue to the top and bottom fairing joints about 1" from the front. Smooth the glue into the joints and hold with your fingers until the glue begins to set. Continue working back until the whole fairing is glued snugly against the body. Apply a bead of glue to both fairing-body tube joints. Smooth the glue with your finger. Apply similar glue reinforcements to the joints where the wing exits from the fairing. The remaining fairing is attached to the opposite side of the rocket in the same manner.

11

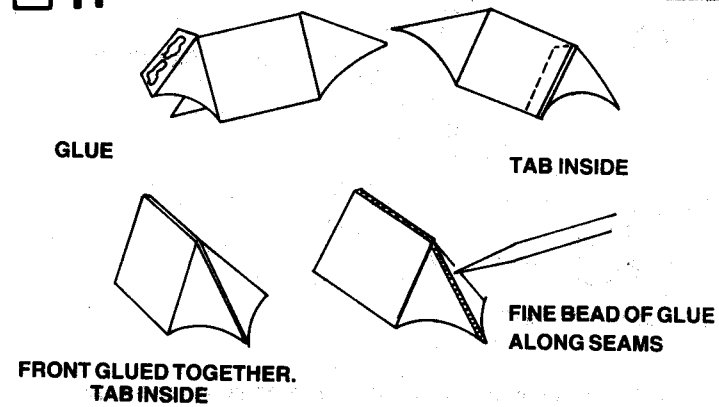

Fold the canopy on the scored lines. Fold over all the way at each score and partially unfold. This will make it easier for the part to maintain final shape. Apply a small amount of glue to the tab at the rear of the canopy. Fold the unit so the tab fits inside the opposite side of the canopy. Hold until the glue sets. Next, glue the front together (tab inside). Use a pointed stick to apply a very thin bead of glue to the folded seams. Set the canopy aside until glue dries.

12

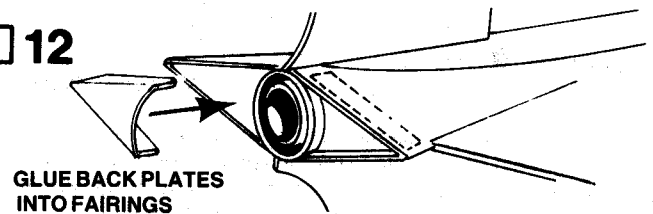

Fold over the tabs on the back plates. Apply glue to the inside of the fairings. Push the plates, tabs first, into the fairings. Carefully push the plates in until they are about 1/16" inside the rear of the fairings. Using a sharp stick, apply a fine bead of glue all around the plate-fairing joints.

13

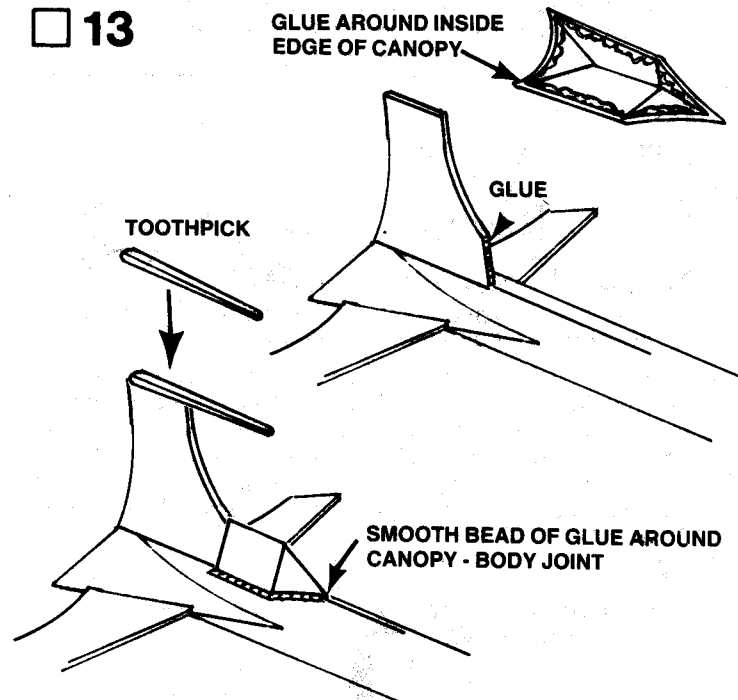

The canopy is glued to the top of the body with its rear edge against the rudder. Apply a bead of glue to the flat, front portion of the rudder. Apply a light bead of glue to the inside edges of the canopy. Set the canopy in place and align it on the center of the body. Hold the canopy in place until the glue dries. Apply a bead of glue around the canopy-body joints and smooth the glue with your finger. Glue the remaining toothpick to the top of the rudder with the flat side of the toothpick against the rudder.

14

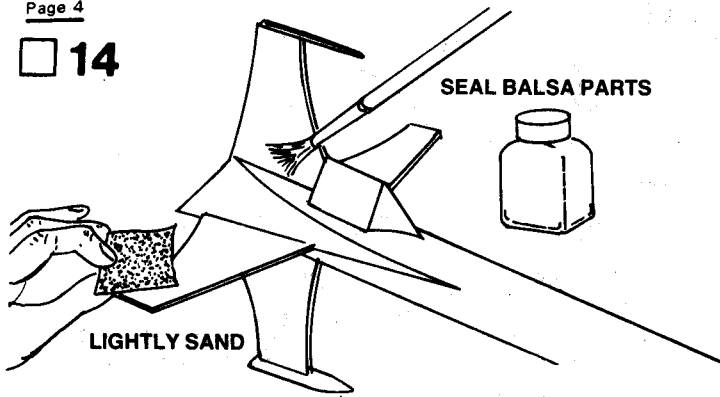

Apply a coat of sanding sealer to the balsa parts. When the sealer is dry, lightly sand the sealed surfaces. Repeat the sealing and sanding process until the parts look and feel smooth. Lightly sand the glue joints on the fairings and canopy.

15

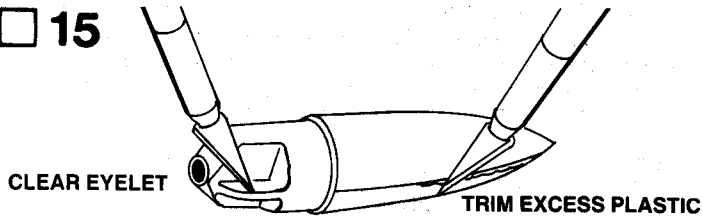

Trim or sand any excess plastic from around the sides of the nose cone (part I). Use a sharp knife to remove any excess plastic from the inside of the molded eyelet at the rear of the nose cone. Wash the nose cone with lukewarm soapy water, rinse well, and dry.

NOTE: Nose cone should separate easily from rocket body tube, but should not be extremely loose. If fit is too tight, sand inside of body tube and shoulder of nose cone with fine sandpaper. If fit is too loose, add a wrapping of transparent tape or masking tape to the shoulder of the nose cone.

16

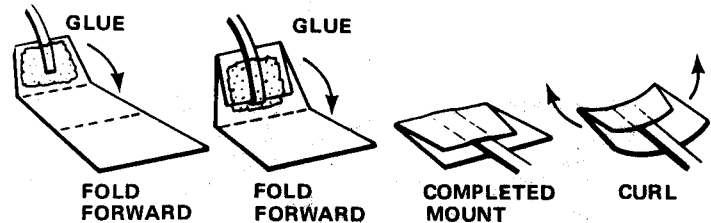

Cut out the shock cord mount from page 5 of these instructions. Fold on dotted lines, then unfold and apply glue to Section 1. Lay the end of the shock cord (part J) into the glue. Fold over and apply glue to the back of Section 1 and the exposed portion of Section 2. Fold again to complete mount. Curl the edges of the mount up so it will match the contour of the body tube and hold with your fingers until the glue sets.

17

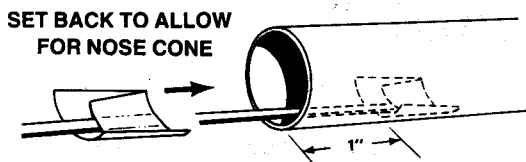

Use a finger or stick to apply glue to the inside of the front of the body tube, 1" to 2" from the front of the tube. Press the shock cord mount firmly into position in glue far enough from the front edge of the tube to allow clearance for the nose cone to fit into place. To insure a good bond use a stick or your finger to smear a film of glue over the mount and surrounding area in the body tube.

18

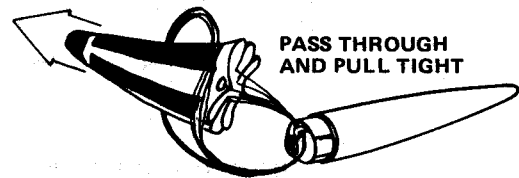
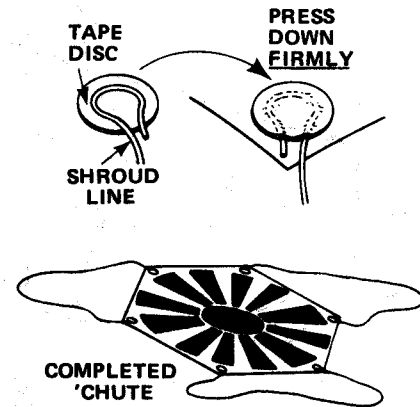

Cut out the parachute (part K) on its edge lines. Cut three equal lengths of shroud line (part L). Attach line ends to the top of the parachute with tape discs (part M) as shown. Form a small loop in the end of a shroud line. Holding loop, gently center loop inside tape disc on the sticky side. Then carefully press tape disc onto its proper place on the top of the parachute. Firmly press the tape disc into place until both tape disc and parachute material are molded around the shroud line loop. Repeat for other shroud line ends and tape discs. Pass the shroud line loops through the loop on the nose cone. Pass the parachute through the loop ends and pull the lines tight against the nose cone. Tie the free end of the shock cord firmly to the nose cone loop. A square knot or strong double knot should be used. Pack chute and shock cord into body and socket nose cone in place.

19

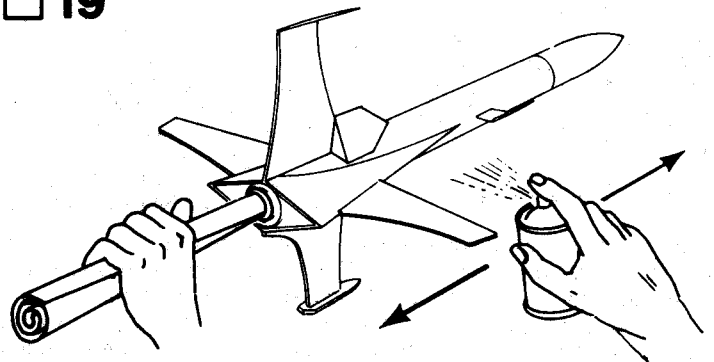

USE ROLLED PAPER FOR ROCKET HOLDER

Paint the entire model gloss yellow. Follow instructions on the spray can for best results. We recommend spray enamel. Do not paint the model with lacquer paint. Shake can before spraying. Hold the can straight up and spray in long, smooth "strokes". Spray the model with several light, dry mist coats of paint to avoid "runs". Shake can periodically. Be sure paint is completely dry before applying decals.

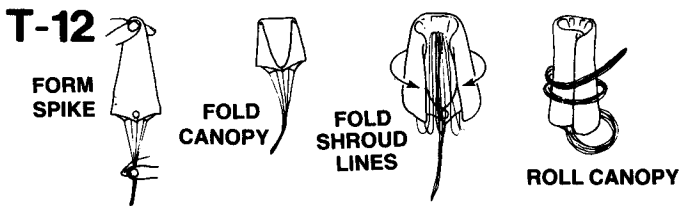

Hold the parachute at its center and pass the other hand down it to form a "spike" shape. Fold this spike in half. Fold shroud lines back along parachute and then back down to lower edge of parachute to reduce length of shroud line "left over". Roll parachute into tube shape to fit easily into body. Any remaining shroud line should be loosely wrapped around parachute. Pack 'chute into the body tube on top of the wadding. Pack the shroud lines and shock cord in on top of the parachute and slip the nose cone into place.

NOTE: DO NOT pack parachute until you are actually ready to launch. For maximum parachute reliability, lightly dust the 'chute with ordinary talcum powder before each flight, especially in cold weather.

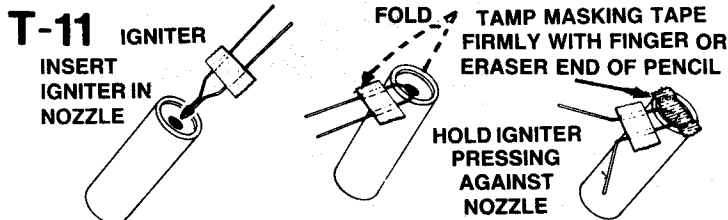

Select an engine and install an igniter as directed in the engine instructions. The engines recommended for use with this rocket are the A8-3, B4-4, B6-4, B8-5 and C6-5 made by Estes. Use a B4-4 engine for your first flight.



Galactic taxi

A DAMON COMPANY

ESTES INDUSTRIES
PENROSE, CO 81240 USA

T-10

ENGINE HOOK MUST LATCH SECURELY

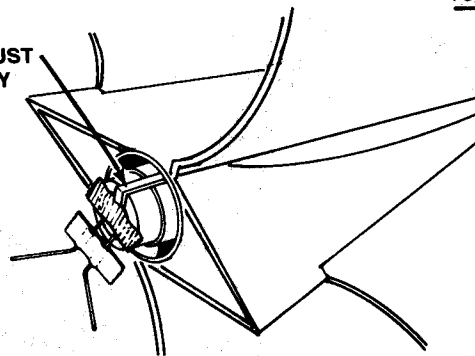

Insert engine into rocket engine mount. Engine hook must latch securely over end of the engine.

T-9 Disarm the launch panel—REMOVE SAFETY KEY!

T-8

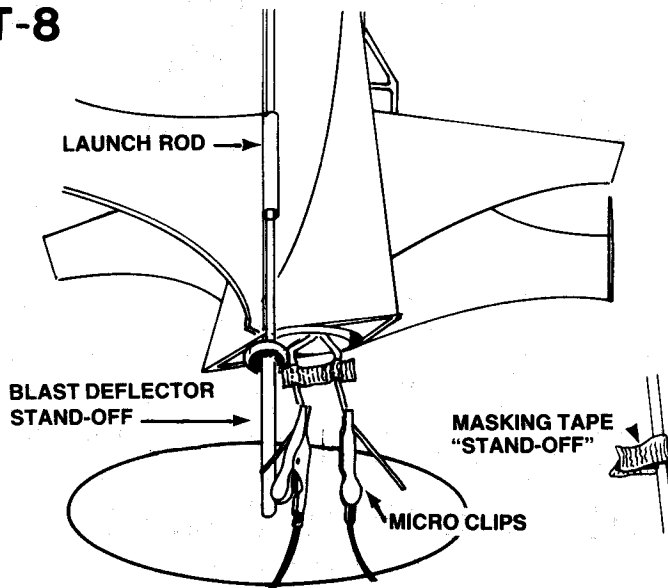

Slide the launch rod through rocket launch lug. Make sure the rocket slides freely on the launch rod. The rocket must be supported by a "stand-off" to keep the igniter wires from touching the metal blast deflector. If your launch system does not have a stand-off, wrap a piece of masking around the launch rod to support the rocket. Clean the micro-clips and attach them to the igniter wires. Attach the clips as close to the engine as possible. Arrange the clips so they do not touch each other or the metal blast deflector.

T-7 Clear the launch area. Alert recovery crew and trackers. Check for low flying aircraft and unauthorized persons in the recovery area.

T-6

Arm the launch panel—INSERT SAFETY KEY!

5-4-3-2-1-LAUNCH!!

Repeat Countdown Checklist for each flight.

MISFIRE PROCEDURE

Disarm the launch panel. Wait one minute before approaching the rocket on the launch pad. Remove the rocket, clean the igniter residue from the nozzle of the engine, and carefully install a new igniter. Repeat the Countdown Checklist.

Failure of the rocket engine to function properly is nearly always caused by a failure to install the igniter correctly. This failure permits the igniter to heat and burn into two pieces without igniting the engine.

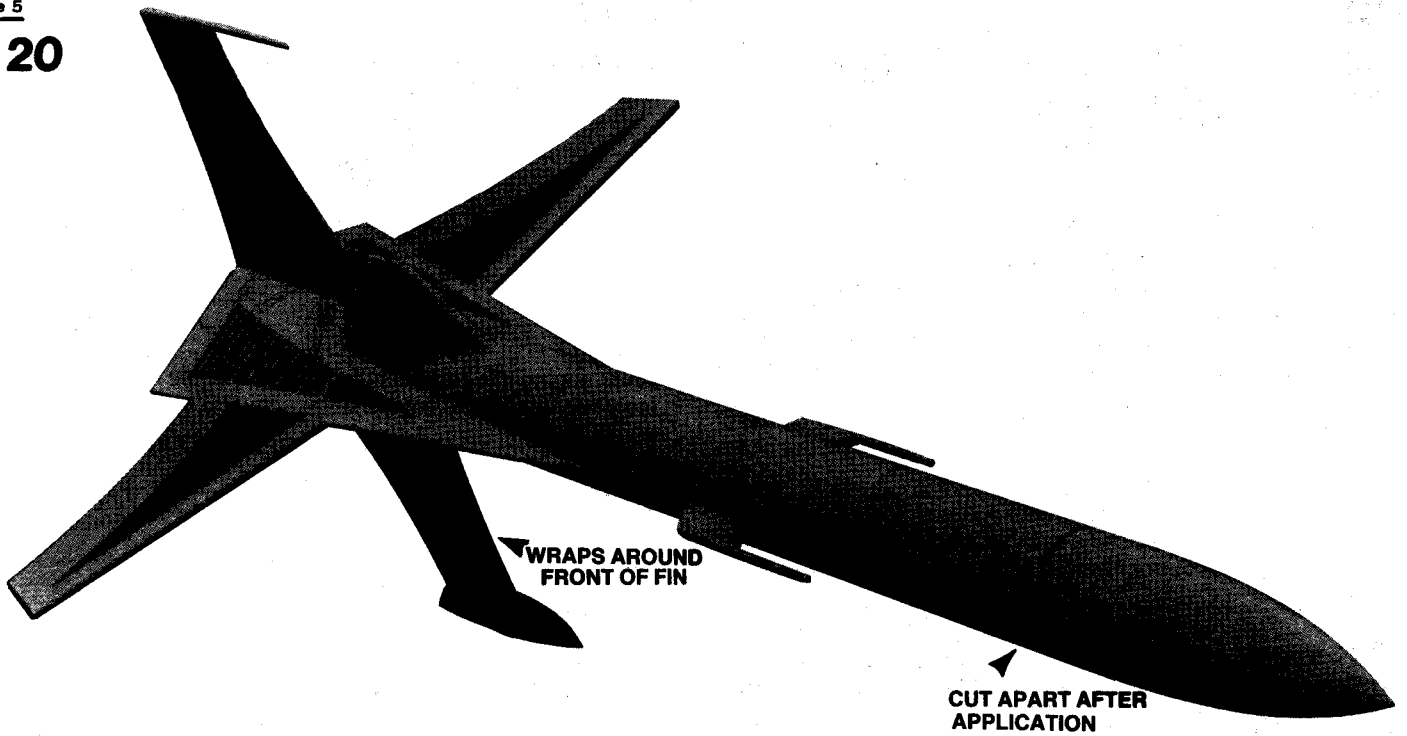

When all paint is dry, apply the decals (part N) in the positions shown. (A) Cut only one decal at a time from sheet. (B) Submerge decal in lukewarm water until decal slides off backing paper (usually 15 to 30 seconds). (C) Gently slide decal from backing paper onto model. (D) Move decal into exact position and carefully blot away excess water with a soft cloth. (E) If the decal "sticks" before you have it in position, apply water over the decal with a brush.

This will permit the decal to be moved. (F) Smooth out all wrinkles and air bubbles before the decal dries. Refer to the photograph for decal positions. The decal for both sides of the ventral fin is in one piece. Wrap the decal around the front of the fin and smooth back along sides. The stripes that fit along both sides of the forward body and nose cone are applied as single units. After the decals are dry, cut them apart at the nose cone separation line.

LAUNCHING COMPONENTS

To launch your rocket you will need the following items:

- An Estes model rocket launching system
- Flame resistant recovery wadding (Estes Cat. No. 2274)
- Estes A8-3, B4-4, B6-4, B8-5, or C6-5 model rocket engines. Use a B4-4 engine for your first flight.

Be sure to follow the HIAA-NAR* Model Rocket Safety Code when carrying out your model rocket activities.
 *HIAA—Hobby Industry of America
 *NAR—National Association of Rocketry

COUNTDOWN CHECKLIST

T-13

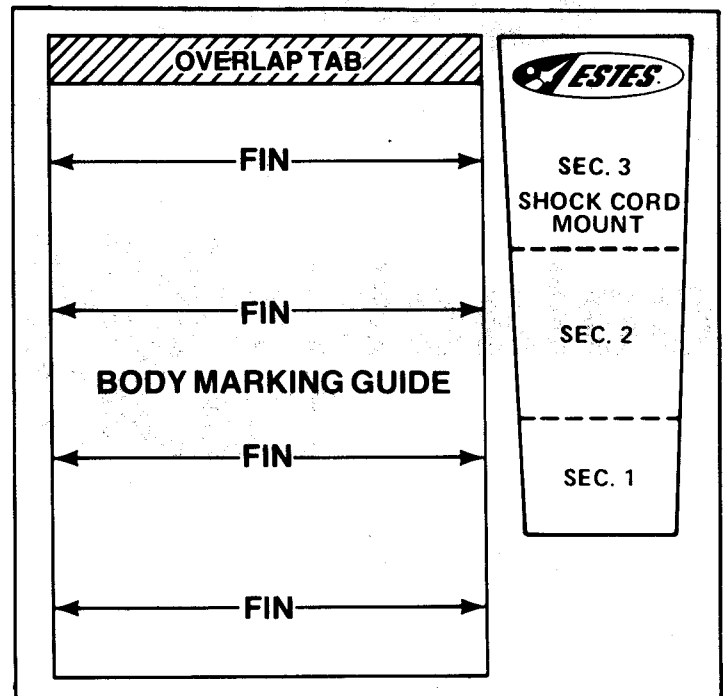
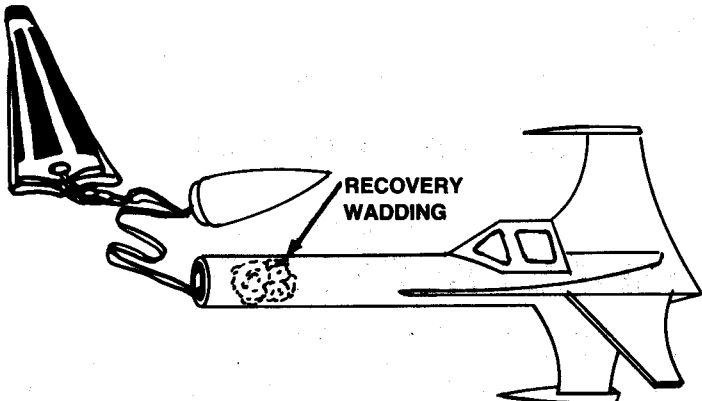

Pack 3 or 4 squares of loosely crumpled recovery wadding into the body tube. Usually this will fill the body tube for a distance equal to about 1-1/2 times its diameter.

Use heavy card stock

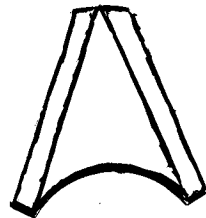
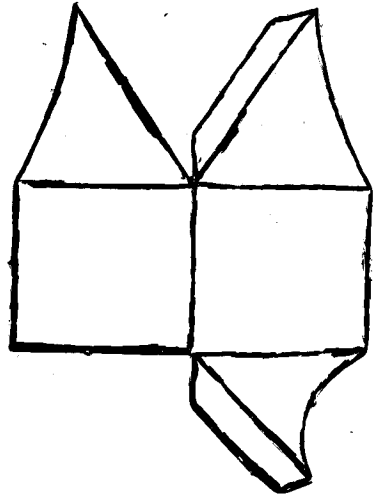
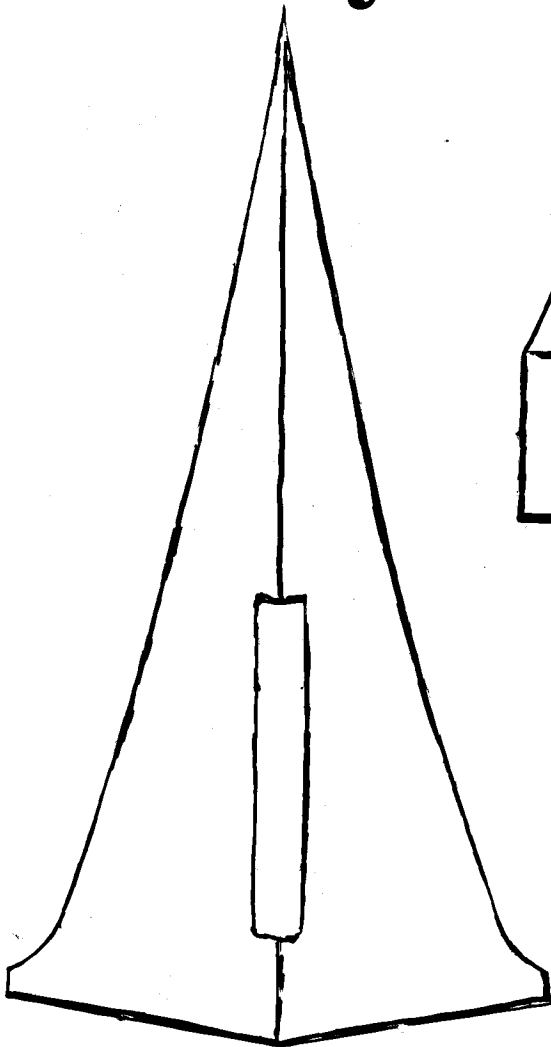

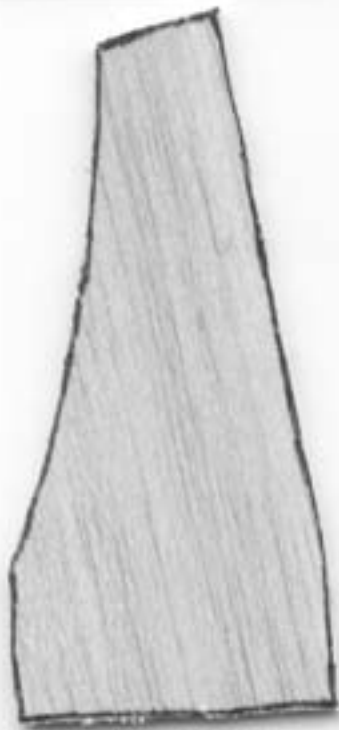
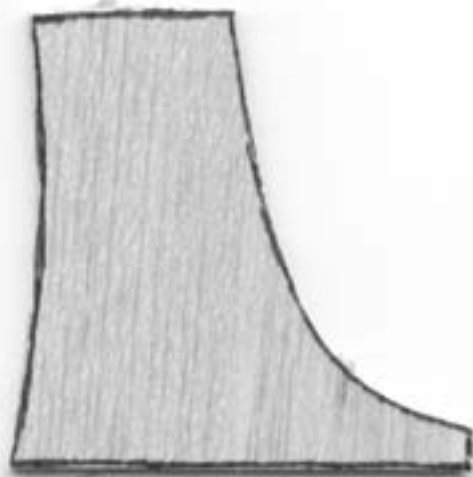
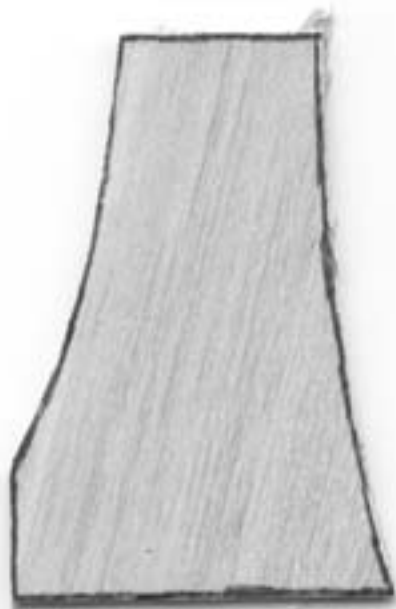



אמנות
אמנות



Galactic Taxi

FLYING MODEL ROCKET

SKILL LEVEL 3

1 Beginner, 2 Intermediate, 3 Expert
4 Advanced, 5 Master

- Interplanetary Shuttle Craft
- Die-Cut Balsa Parts
- Large Two-Color Decal
- Quick Release Engine Mount
- Parachute Recovery
- Plastic Nose Cone

**Flights
To 1000
Feet!**

Length: 18 1/2" (46.7cm)

Dia.: 1 1/2" (3.81cm)

Weight: 1.27 oz. (36g)

Engine Type: 20-25mm Prop. 1/4" x 3/4" 20-25mm, 1/4"

This is a hobby, not a racing sport.
Responsible flying is the goal.
Engine, fuel, motor, and prop safety
equipment are not optional. Adult supervision
is required for those under 18 years of age.
www.flyingmodelrockets.com



#1914

ESTES INDUSTRIES
PHOENIX, AZ 85044 USA