



# ESTES STARLINER

SKILL LEVEL 3 - Recommended for Craftsman Rocketeers.

## BEFORE YOU START

Read all instructions before beginning work on your model. Make sure you have all parts and materials. When you are thoroughly familiar with the assembly procedure, begin construction. Check off each step as you complete it. In each step, test-fit the parts together before applying any glue. If some part doesn't fit properly, sand lightly or build up as required for precision assembly.

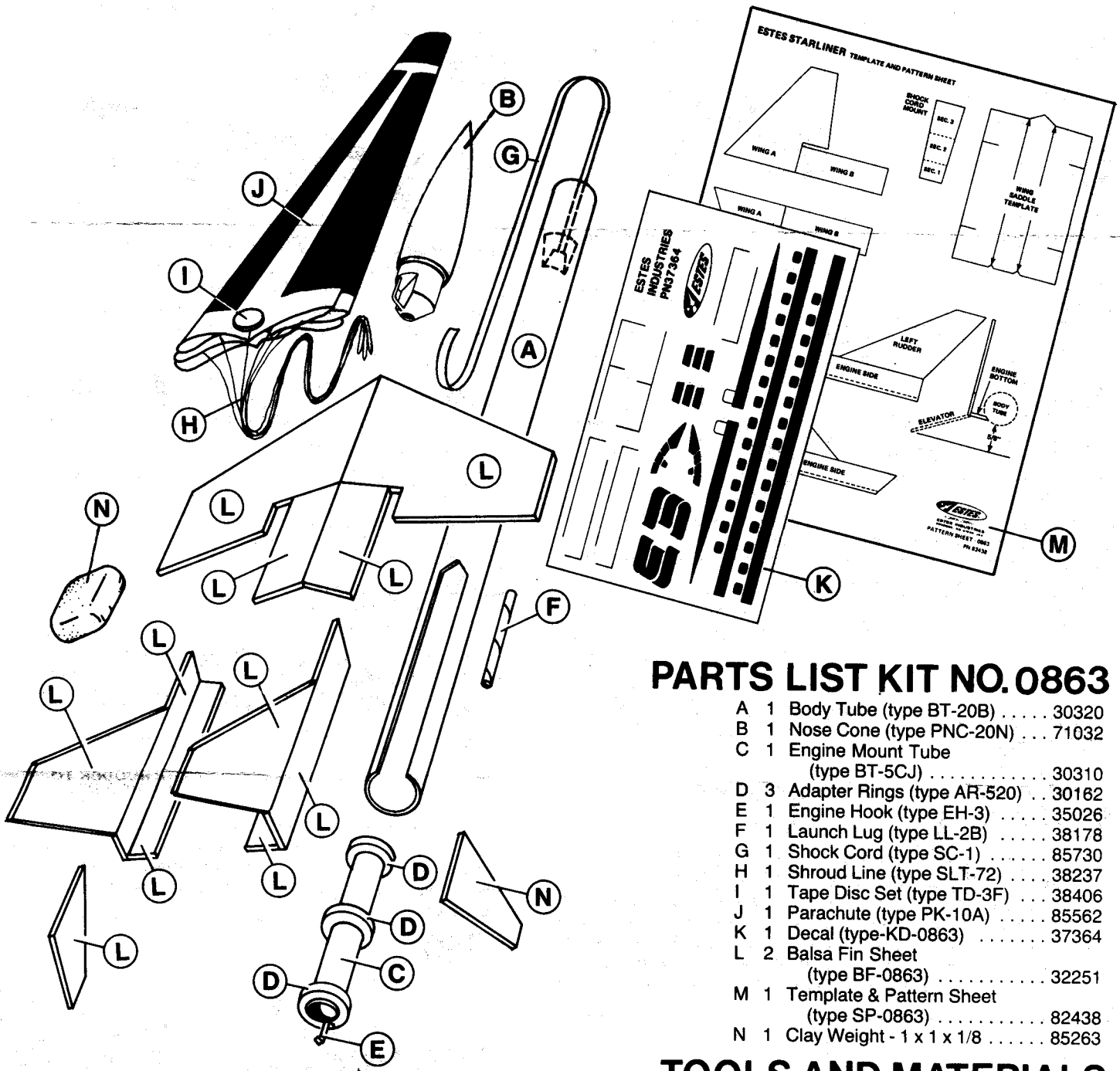

## PARTS LIST KIT NO. 0863

- A 1 Body Tube (type BT-20B) . . . . . 30320
- B 1 Nose Cone (type PNC-20N) . . . . . 71032
- C 1 Engine Mount Tube  
(type BT-5CJ) . . . . . 30310
- D 3 Adapter Rings (type AR-520) . . . . . 30162
- E 1 Engine Hook (type EH-3) . . . . . 35026
- F 1 Launch Lug (type LL-2B) . . . . . 38178
- G 1 Shock Cord (type SC-1) . . . . . 85730
- H 1 Shroud Line (type SLT-72) . . . . . 38237
- I 1 Tape Disc Set (type TD-3F) . . . . . 38406
- J 1 Parachute (type PK-10A) . . . . . 85562
- K 1 Decal (type-KD-0863) . . . . . 37364
- L 2 Balsa Fin Sheet  
(type BF-0863) . . . . . 32251
- M 1 Template & Pattern Sheet  
(type SP-0863) . . . . . 82438
- N 1 Clay Weight - 1 x 1 x 1/8 . . . . . 85263

## TOOLS AND MATERIALS

In addition to the parts included in this kit you will need: An X-Acto type modeling knife with sharp blade, white glue (Elmer's, Titebond, or similar household white glue), scissors, pencil, fine and extra-fine grit sandpaper, sanding sealer, paint brush, masking tape, and gloss white enamel spray paint.

**RECOMMENDED ENGINES:**  
1/2A3-2T A3-2T A3-4T A10-3T



A DAMON COMPANY

**ESTES INDUSTRIES**  
PENROSE, CO 81240 USA

# ASSEMBLY INSTRUCTIONS

1

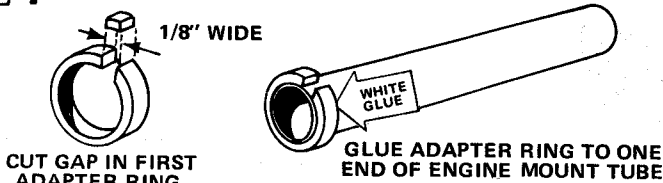

Cut a 1/8" gap in one adapter ring (part D). Glue it to one end of the engine mount tube (part C).

2

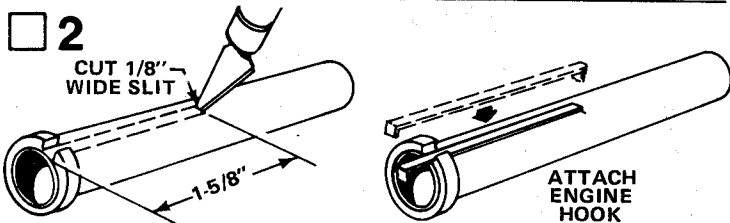

Cut a 1/8" slit in the engine mount tube, directly in line with the gap in the split ring and 1-5/8" from the end that has the split ring. Insert the engine hook (part E) in place.

3

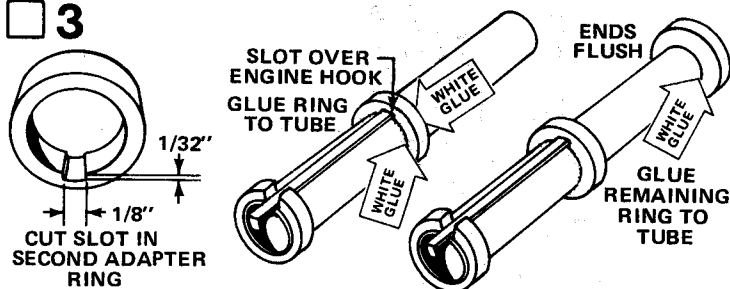

Cut a 1/32" deep x 1/8" wide slot in the inside diameter of a second adapter ring and glue it onto the engine mount tube with the slot over the forward end of the engine hook. Glue the third adapter ring at forward end of engine tube.

4

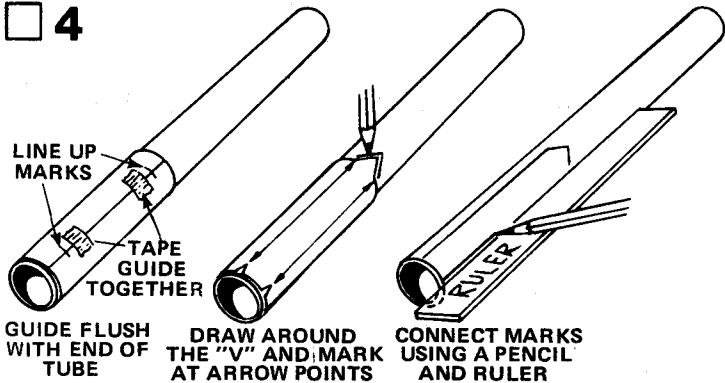

Cut out saddle pattern from the pattern and template sheet (part M). Wrap it around one end of body tube (part A), match guide marks, and tape guide in place. Mark the tube at each arrow point. With back of pattern flush with end of body tube, mark around "V" at front end of pattern. Remove pattern and connect arrow points.

5

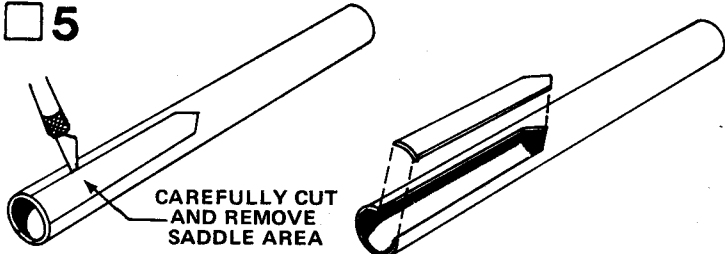

With a sharp X-Acto knife cut out wing saddle area from body tube.

6

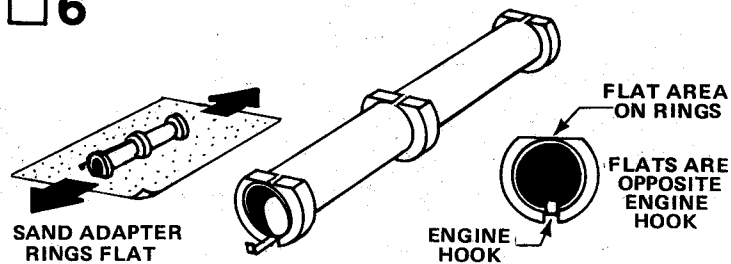

When glue has completely dried on engine tube/adapter ring assembly, cut and sand flats on three adapter rings so the flats on all three rings are flush with the outside of the engine tube and on side opposite the engine hook.

7

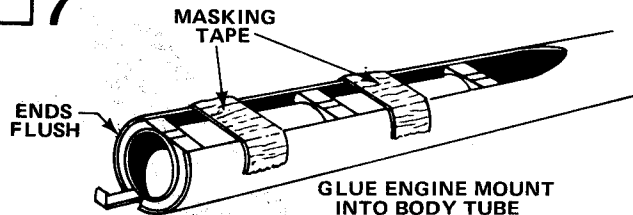

Install engine tube/adapter assembly into the body tube where wing saddle area has been cut out. Make sure flats on adapter rings are flush with each side of the saddle area, and engine tube is flush with end of body tube. Glue unit in place and use masking tape around body tube to hold tube tight around each adapter ring until the glue has dried.

8

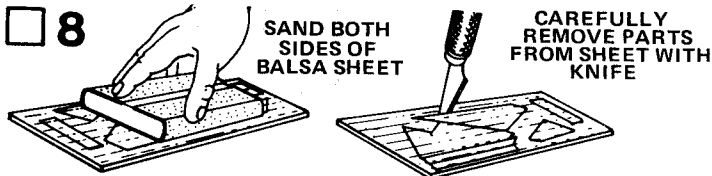

Fine-sand both sides of both die-cut balsa sheets (part L). With a sharp X-Acto knife, carefully remove all parts from both sheets.

9

GLUE WING SECTIONS TOGETHER

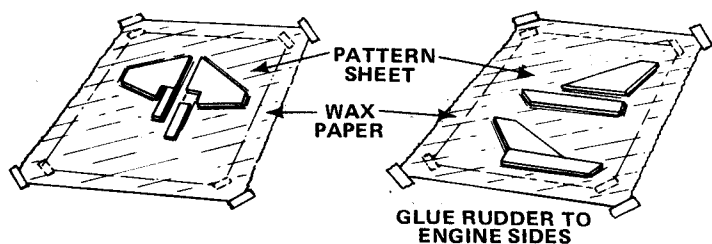

Pin or tape gluing template sheet to a flat board or bench top and cover with wax paper. Glue wings part A to part B and rudders to engine sides as shown on template sheet. Carefully locate each piece over its template drawing to ensure good alignment on final assembly.

10

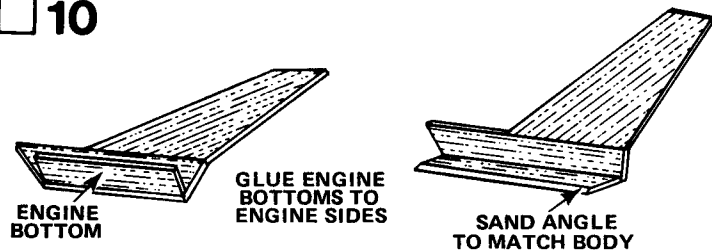

After glue in Step 9 has dried, assemble a die-cut "engine bottom" to each "engine side" as indicated on template sheet. Be sure to keep each engine bottom at 90° to its engine side. When this glue has dried, carve and sand the edges of the engine bottom that fit against body tube to a sharp angle as shown on template sheet.

11

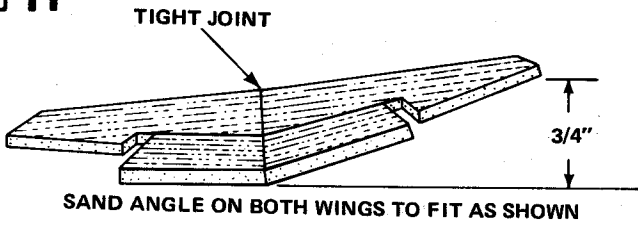

Sand each wing center edge at a 10° angle so that when one wing is flat on your construction board, the other wing makes a tight joint when its tip is elevated 3/4". This will give the wing the correct negative dihedral angle. Glue the two wing assemblies together. Support the wings in this position until the glue dries.

12

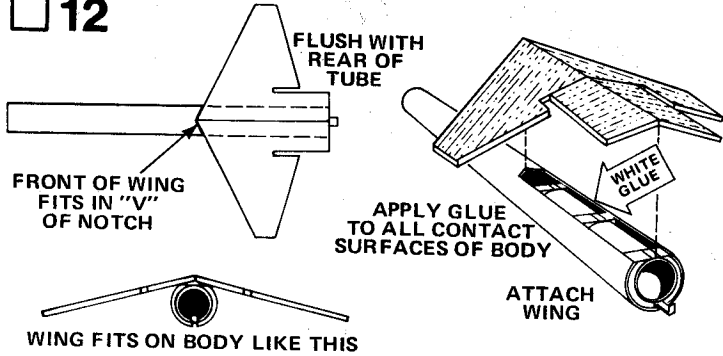

When glue on wing assembly has thoroughly dried, glue wing assembly in place in the wing saddle cut-out area of the body tube. Test-fit the wing to the body tube to make sure it seats tightly to the saddle area. It may be necessary to cut or sand a bit from the flattened adapter rings to make sure wing seats on the cut edges of the body tube. Be sure to get a good glue bond between wing and body tube as the area will be subject to ejection charge pressure.

13 APPLY GLUE TO AREAS SHOWN AND ATTACH TO MODEL

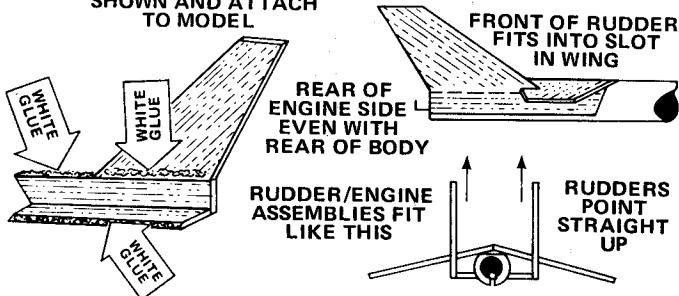

Glue each rudder/engine assembly in place to the wing and body tube. Make sure both rudders are vertical and the rear of the engine sides are flush with the trailing edge of the wing and rear of the body tube.

14

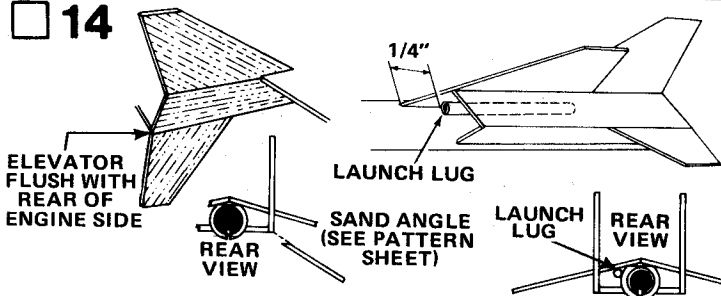

Sand a 60° angle into the root edge of each of the die-cut elevators. Check this angle with the angle shown on the pattern and template sheet. Glue an elevator in place on each engine bottom. To ensure the correct angle, rest the body tube on a 5/8" thick piece of wood or other material. When glue has dried, glue launch lug to the underside of the left wing where it joins the body tube, 1/4" back from wing leading edge.

15

CLEAR EYELET

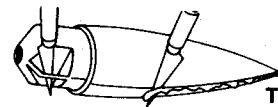

TRIM EXCESS PLASTIC

16

INSERT CLAY

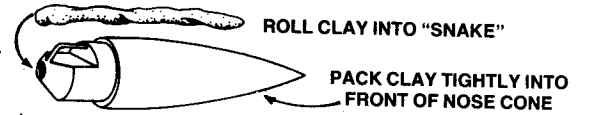

Roll the clay balance weight (part N) between your hands to make a "snake" about 1/8" diameter. Poke the clay through the hole in the rear of the nose cone (part B). Use a pencil or dowel to push the clay forward into the cone until it is packed tightly in the front of the cone.

17



Cut the shock cord mount from the pattern and template sheet. Fold on dotted lines, then unfold and apply glue to Section 1. Lay the end of the shock cord (part G) in the glue. Fold over and apply glue to the back of Section 1 and the exposed portion of Section 2. Fold again to complete the mount. Curl the edges of the mount up so it will match the contour of the body tube and hold with your fingers until the glue sets.

18

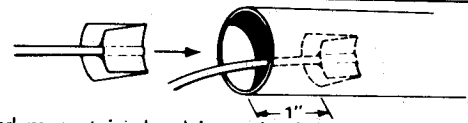

The shock cord mount is glued into the front of the body tube 1" from the end. This allows clearance at the front of the tube for the nose cone to socket into place. Use a stick to deposit a generous dab of glue inside the body tube, 1" from the end. Slide the shock cord mount into the tube and press into the glue. To ensure a good bond, use the stick or your finger to smear a film of glue over the mount and the surrounding area in the body tube. Tie free end of shock cord to the screw eye.

19

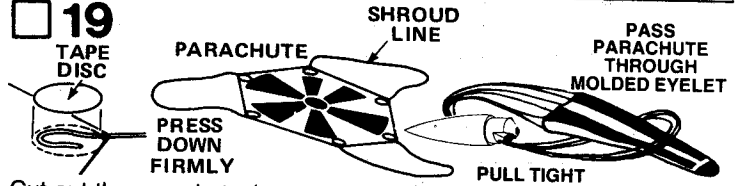

Cut out the parachute (part J) on its edge lines. Cut the shroud line (part H) into three equal lengths. Form a small loop in one end of a shroud line and attach to a corner of the 'chute with a tape disc (part I). Press the tape disc down very firmly over the line. Attach the opposite end of the shroud line to an adjacent corner of the 'chute. Attach the remaining shroud lines in the same manner. Pass the shroud line loops through the loop on the nose cone. Pass the parachute through the loop ends and pull the lines tight against the nose cone. Tie the free end of the shock cord firmly to the nose cone loop. A square knot or strong double knot should be used.

20 PAINTING AND DETAILING

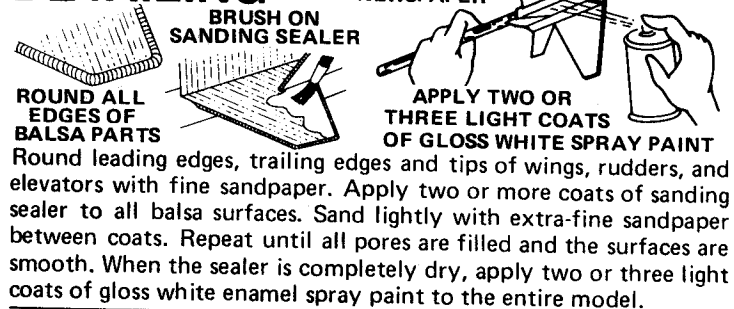

Round leading edges, trailing edges and tips of wings, rudders, and elevators with fine sandpaper. Apply two or more coats of sanding sealer to all balsa surfaces. Sand lightly with extra-fine sandpaper between coats. Repeat until all pores are filled and the surfaces are smooth. When the sealer is completely dry, apply two or three light coats of gloss white enamel spray paint to the entire model.

# DECAL PLACEMENT

□ 20

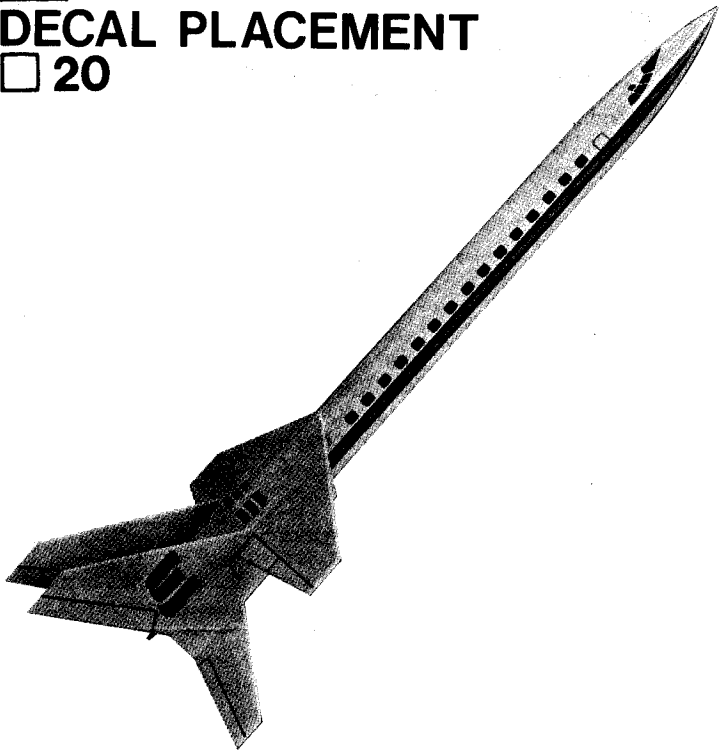

After the paint is completely dry, apply decals (part K) in the positions shown. To apply decal, cut one decal at a time from the sheet. Submerge decal in water for 15 to 30 seconds (until decal slides on backing paper). Gently slide decal from backing paper onto model. Move decal into exact position and carefully blot away excess water with a soft cloth. If the decal "sticks" before you have it in position, apply water over the decal with a brush. This will permit the decal to be moved. Smooth out all wrinkles and air bubbles before the decal dries. We recommend that the completed model be sprayed with Testor's "DullCote" to kill the decal shine and protect the model's finish.

## LAUNCHING COMPONENTS

To launch your rocket you will need the following items:

- An Estes model rocket launch system
- Parachute recovery wadding (Estes Cat. No. 2274)
- Recommended Engines: 1/2A3-2T, A3-2T, A3-4T, or A10-3T. Use a 1/2A3-2T engine for your first flight.

Be sure to follow the HIAA-NAR\* Model Rocket Safety Code when carrying out your model rocket activities.

\*HIAA -- Hobby Industry Association of America  
NAR -- National Association of Rocketry

## COUNTDOWN CHECKLIST

**T-14** Pack 2 squares of loosely crumpled recovery wadding into the rocket body tube.

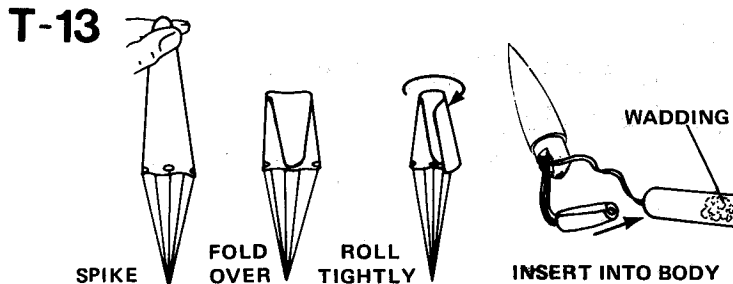

Hold the parachute at its center and pass the other hand down it to form a "spike" shape. Fold this spike in half. Roll parachute into tube shape to fit easily into body. Pack 'chute into the tube on top of the wadding. Pack the shroud lines and shock cord in on top of the parachute and slip the nose cone into place.

**NOTE:** DO NOT pack parachute until you are actually ready to launch. For maximum parachute reliability, lightly dust the 'chute with ordinary talcum powder before each flight, especially in cold weather.

### T-12

**NOTE:** Nose cone should separate easily from rocket body tube, but should not be extremely loose. If fit is too tight, sand inside of body tube and shoulder of nose cone with fine sandpaper. If fit is too loose, add a wrapping of transparent tape or masking tape to the shoulder of the nose cone.

### T-11

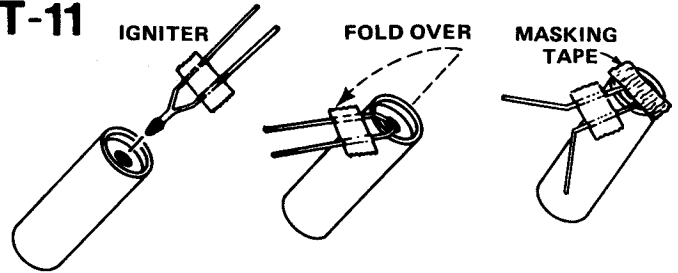

Select an engine and install an igniter as directed in the engine instructions.

### T-10

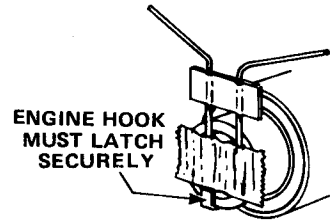

Insert engine into rocket. Engine hook must latch securely over end of the engine.

**T-9** Disarm the launch panel -- REMOVE SAFETY KEY!

### T-8

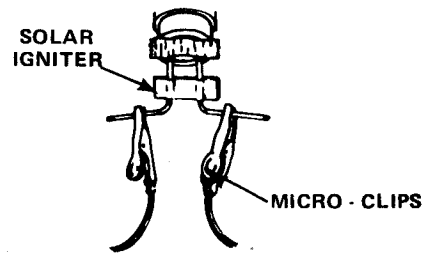

Place rocket on launch pad, making sure rocket slides freely on launch rod. Clean the micro-clips and attach them to the igniter wires as close to the engine nozzle as possible. Arrange the clips so they do not touch each other or the metal blast deflector.

**T-7** Clear the launch area, alert recovery crew and trackers. Check for low flying aircraft and unauthorized persons in the recovery area.

**T-6** Arm the launch panel -- INSERT SAFETY KEY!

## -5-4-3-2-1-LAUNCH!!

Repeat the Countdown Checklist for each flight.

## MISFIRE PROCEDURE

Occasionally the igniter will heat and burn into two pieces without igniting the engine. This is almost always caused by a failure to install it correctly. REMOVE SAFETY KEY from launch panel, remove the model, clean the igniter residue from the engine nozzle, and install a new igniter. Repeat the Countdown Checklist.

# ESTES STARLINER TEMPLATE AND PATTERN SHEET

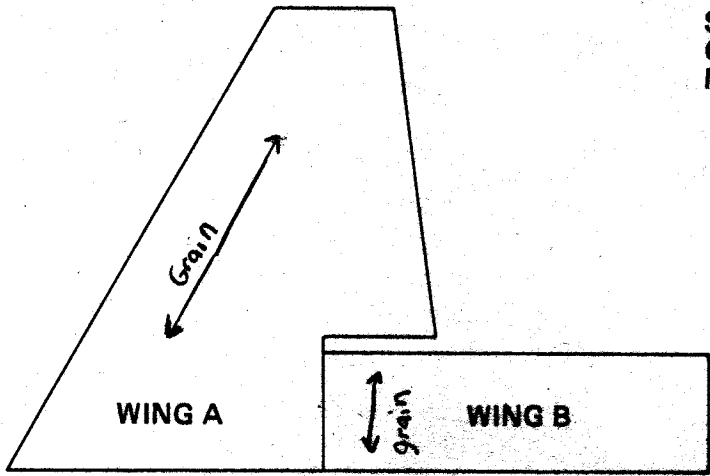

SHOCK  
CORD  
MOUNT

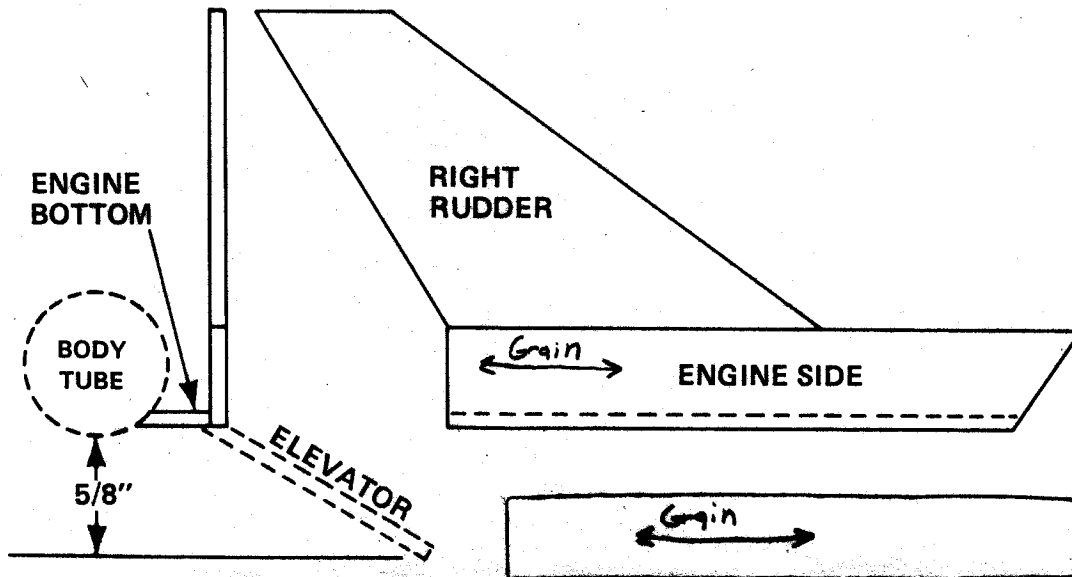
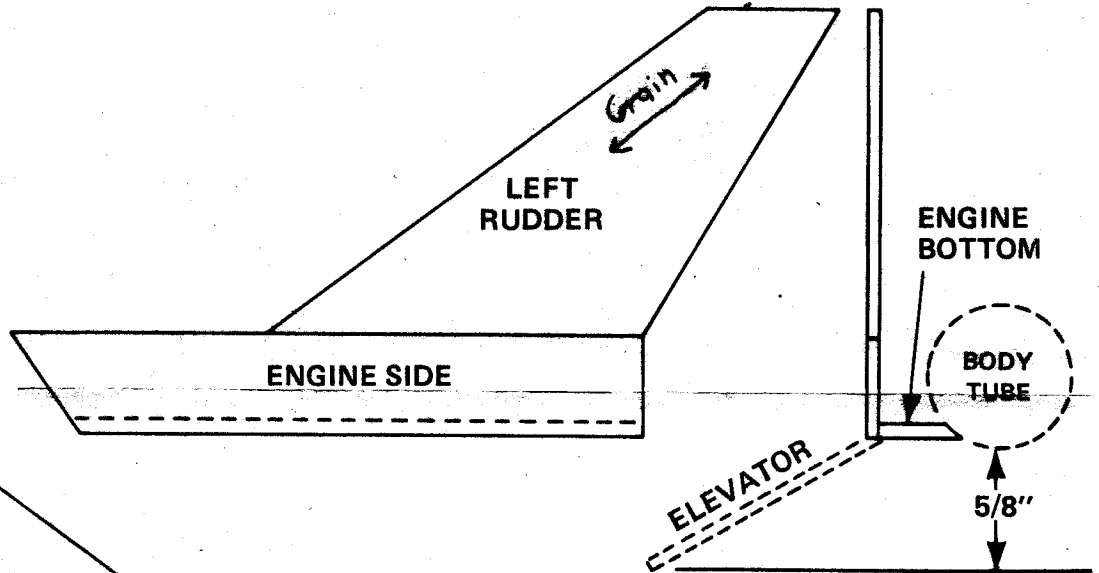
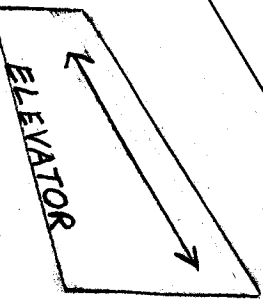
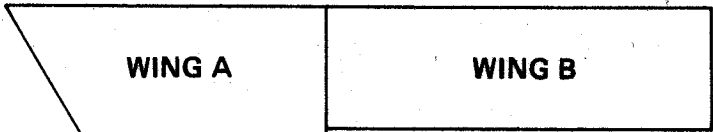
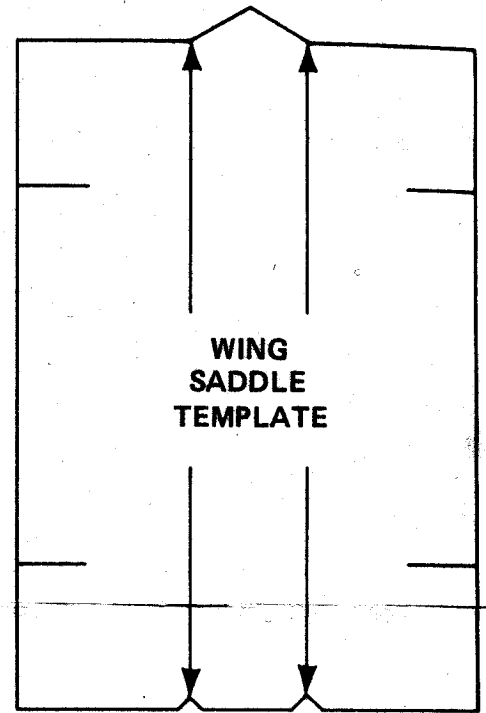
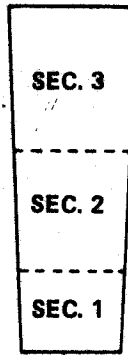

A DAMON COMPANY

ESTES INDUSTRIES  
PENROSE, CO 81240 USA

PATTERN SHEET - 0863

PN 82438

**ESTES  
INDUSTRIES  
PN37364**

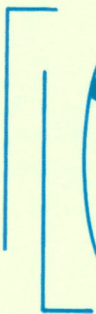

# ESTES STARLINER FLYING MODEL ROCKET

**SKILL LEVEL 3**

1-Beginner 2-Intermediate 3-Craftsman  
4-Advanced 5-Expert

- Futuristic Space Transport Ship
- Mini-Engine Powered
- Beautiful Display Model
- Flights Up To 600 Feet!
- Die-Cut Balsa Fins
- 10" Parachute Recovery
- Realistic Kit Decals

Length: 12.6" (32 cm)

Dia: .726" (18.7 mm)

Wt: .9 oz. (25 g)

Engines:

1/2A3-2T (1st FIL)

A3-2T A3-4T

A10-3T

This is a hobby kit requiring assembly. Recommended for ages 10 to adult. Engines, launch system, glue and finishing supplies are not included. Adult supervision is suggested for those under 12 years of age when flying model rockets.

#0863



A UNION COMPANY



ESTES INDUSTRIES  
PENROSE, CO 81240 USA