

# HELICHOPPER

## DESCRIPTION:

The Helichopper is a model rocket designed for recovery using rotating helicopter type blades. The blades are folded inside the main body tube and are ejected at apogee by the rocket engine.

## NOSE CONE ASSEMBLY:

Cut 3 pieces of fine wire exactly  $\frac{3}{4}$ " long. Using a large pin, punch 3 holes  $\frac{1}{4}$ " from bottom of triangular piece in each corner. Push the three wires through the holes until they are evenly spaced as shown on drawings. Wires cannot extend beyond round part of adapter or it will not fit body tube. Fill triangular parts of plastic adapter with epoxy. When dry, drill a small hole in the center through the bottom.

Push heavy wire through this hole and put a bead over it. Bend the wire to hold bead in place. Put another bead on the wire from the bottom. Pull tight and place a small piece of tape below the bead to hold the entire assembly in place. Bend an eye in the lower part of the wire and attach a rubber band in the eye so it will not come off during ejection.

Put a thin coat of plastic cement around inside of nose cone and insert adapter. Use cement sparingly as it will melt nose cone.

Punch two holes with a pencil  $\frac{1}{2}$ " apart in the gauze shock cord anchor and thread cord into anchor as shown. Smear glue with a brush or "Q" Tip in body tube about the size of the anchor  $1\frac{1}{2}$ " from end. Insert shock cord and anchor into body tube and push into glue with a pencil until securely set in place. Tie other end to rubber band on nose cone assembly.

## FINS:

Sand fins to airfoil shape. The part that glues to the body should be straight and square. Using the fin spacing guide, center the end of the body tube in the circles and mark at the 3. Use a "V" notch of a drawer or door frame and draw a line at the mark parallel to the body. Glue the three fins on this line flush with the bottom of the body. When dry, apply a glue fillet on each side of all fins.

## ENGINE MOUNT:

Glue one centering ring  $\frac{1}{4}$ " from end of engine mount away from holes. Glue other centering ring 3" from bottom in middle of engine mount so that holes are above ring. Take a square of toilet tissue and soak it in white glue. Stuff it into the end of mount with the holes so that it blocks the end of tube completely but does not block the holes. Apply more glue or paper as necessary for a tight seal. Put glue on centering rings and slide 3" RB90 tube over until bottom of tube is flush with lower ring. Using a "Q" Tip or brush, smear glue around inside of mount 2" from open end. Insert engine block and push it forward with an engine until  $\frac{1}{8}$ " of engine protrudes. With a "Q" Tip or brush smear white glue inside of main rocket body about 2" from end. Insert engine mount until it is flush with end of main body.

## FINISHING:

Finish rocket by filling all surfaces with sanding sealer. Coat several times sanding between coats until smooth. Paint entire rocket except nose cone or blades.

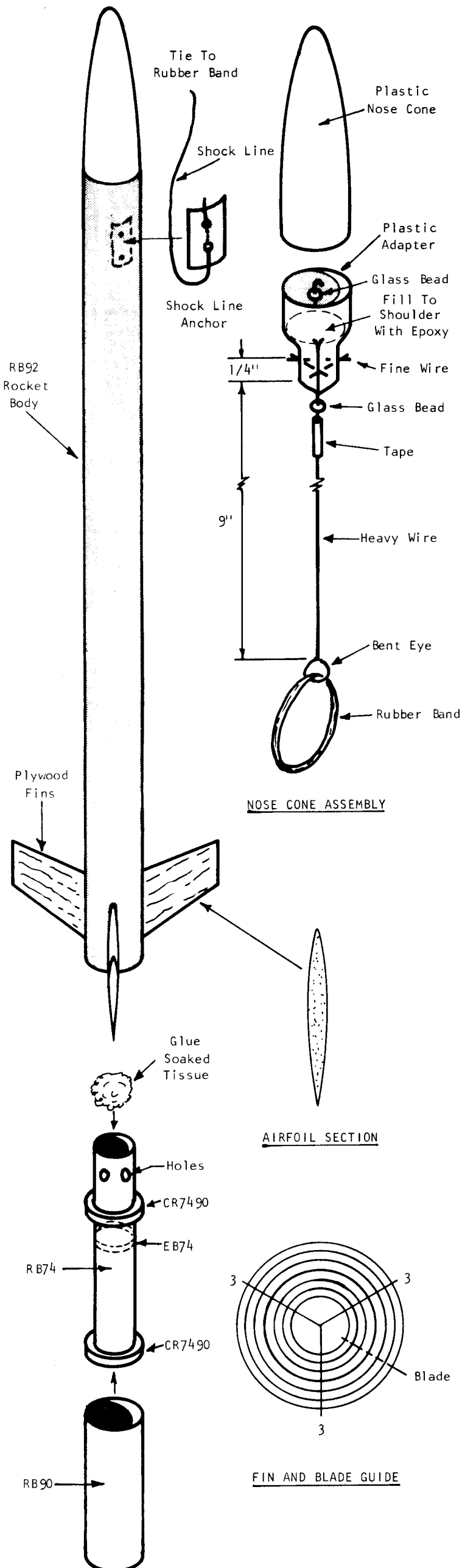

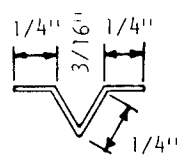
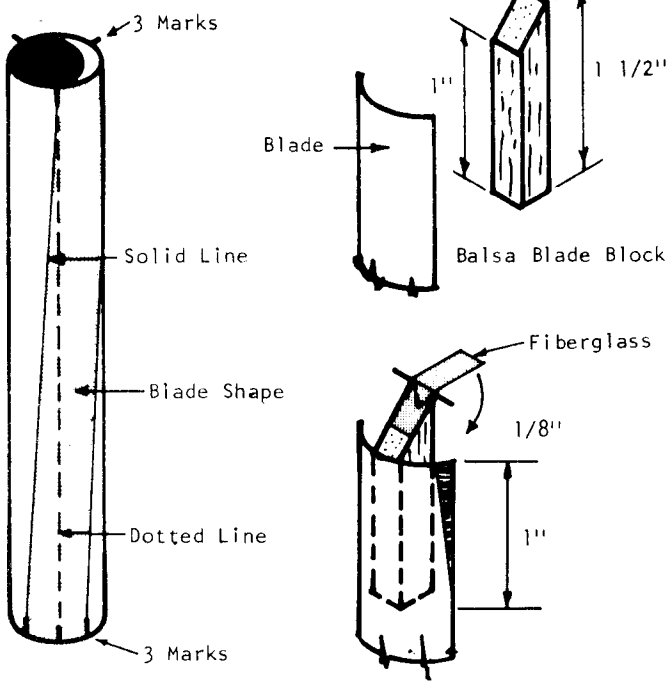

BLADE CONSTRUCTION

BLADE CONSTRUCTION:

Blades are cut from a 9 1/2" RB90 body tube. Place body tube over the fin spacing guide and mark at each 3. Draw a dotted line the full length of the body tube using a "V" notch of a drawer or door frame as a guide. Place other end of body tube with this line on fin spacing guide at point marked "Blade". Mark at each 3. Using a straight edge connect marks at each end of tube with a solid line. These lines should be at a slight angle from the dotted line. Cut along solid lines to form blades.

Cut three balsa blade blocks 1 1/2" long, then cut 1/2" bevel as shown. Using epoxy, glue these blade blocks to the blades so that the 1/2" angle extends beyond the blade.

Cut three pieces of thin wire 1" long. Bend as shown in bending diagram. Cut three pieces of RMI (Fiberglass) to 3/16" x 1 1/4" long. Put epoxy on end of blade block and set half of fiberglass on beveled side. Place "V" part of wire on flat side of blade block so that ends of wire are parallel to knife edge. Fold fiberglass over wire and onto blade block. After epoxy dries, cover entire fiberglass area with a thick coat of epoxy. Trim off blades 1/8" x 1" as shown.

BLADE ASSEMBLY:

Slip rubber band over long wire until it hits triangular part of nose cone. Pull over one set of wires in the corner so that one part of rubber band is under one set of wires, and other parts are over the other two sets of wires.

Insert wires from blade into rubber band opposite where rubber band goes under the wires.

Put blade wire under wires as shown and pull rubber band tight at the same time hooking over end of balsa blade block. Blade should not hinge at the wires and snap almost to the open position.

Repeat Steps 1, 2 and 3 until all blades are in position.

POP LAUNCH LUG INSTRUCTIONS:

Cut one piece of wire 1 1/2" long and bend to shape of top wire. Bend remaining piece of wire in half to hairpin shape of bottom wire.

Cut paper tape into two equal pieces. Peel off backing and wrap around top and bottom wires and launch lug as shown. Make sure wires are aligned on same side of launch lug.

Bend bottom wire to hook around two fins so that launch lug is centered between fins. Hook launch lug over fins and mark body tube 1/4" from tip of top wire. Drill or punch hole at this point and bend front wire downward to fit easily. Adjust so that launch lug is snug but will pop off easily when pushed on top.

The pop launch lug is always attached after the rocket is prepared for launching complete with engine, recovery device and nose cone installed. To use pop launch lug, slide lug over rod, slip a 1" piece of plastic tubing, or wrap top of rod with 2 or 3 turns of masking tape. Rod must be tight on launch pad. After rocket leaves pad the pop lug will remain on the rod. The rocket can be reattached to the lug without removing the lug from the rod.

FLYING INSTRUCTIONS:

The Helichopper is designed to be flown with A8-5, B4-6, B6-6 and C6-7 18 mm dia. engines. The special baffle system absorbs most of the ejection heat. However, it is recommended that a piece of masking tape be placed over the ejection end of the engine and one piece of wadding be placed in the body tube to help hold down the heat. Put talcum powder in the tube and on the rotors. Hold nose cone and allow rocket to dangle. Fold rotors carefully and allow shock cord to fall inside body tube as rotors are inserted slowly. Make sure rotors do not bind inside tube.

Following engine manufacturer's safety instructions, install an igniter into engine. Wrap engine with tape until it fits snugly into the body tube. Push in place snug against engine block. Place rocket on the launch rod, attach igniter clips and count-down and launch.

Bending Diagram

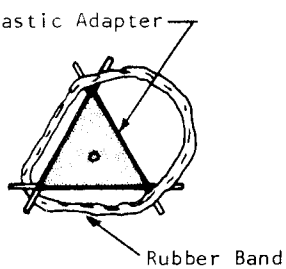

STEP 1

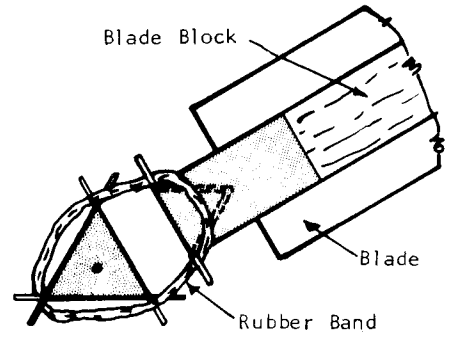

STEP 2

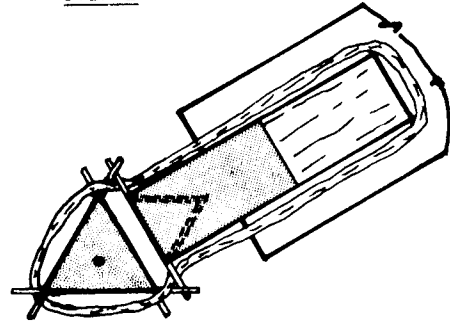

STEP 3

BLADE ASSEMBLY

Viewed from bottom

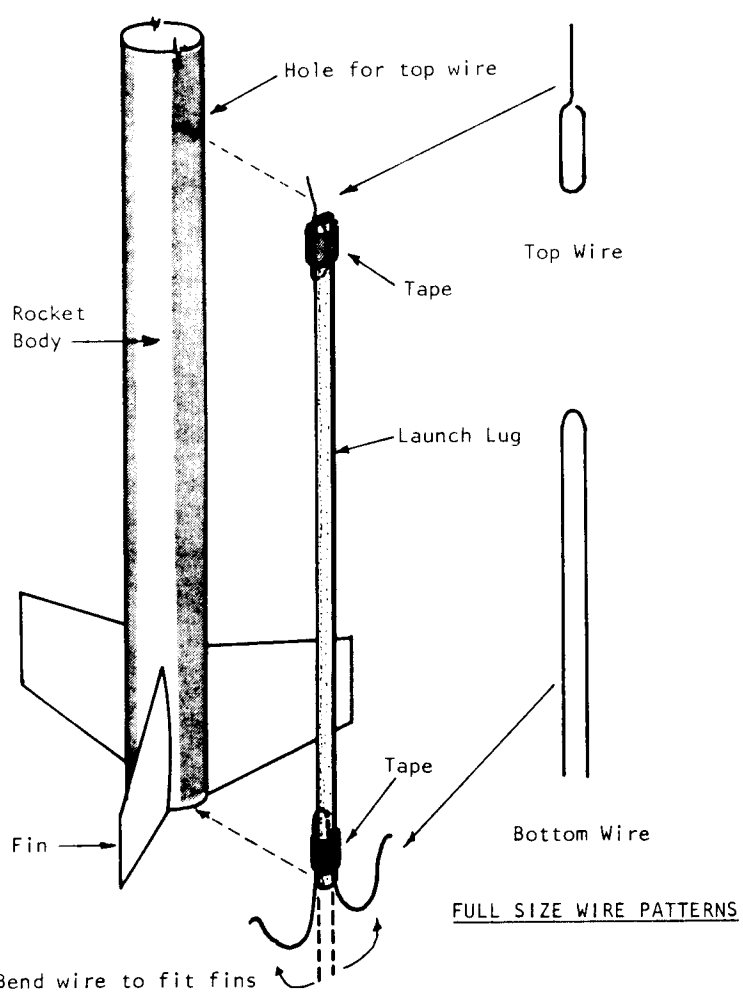

FULL SIZE WIRE PATTERNS

2 13  
9 20  
6 27

2

2 3  
9 10  
16 17  
23 24  
30

3

1  
7 8  
14 15  
21 22  
28 29

4

4 5  
11 12  
18 19  
25 26

2 3  
9 10  
16 17  
23 24  
30 31

5

6 7  
13 14  
20 21  
27 28

ER

3 4  
10 11  
17 18  
24 25

6



14 15 16  
21 22 23  
28 29 30

**JANUARY**  
4 5 6  
11 12 13  
18 19 20  
25 26 27

**FEBRUARY**  
4 5 6  
11 12 13  
18 19 20  
25 26 27

**MARCH**  
1 2 3  
8 9 10  
15 16 17  
22 23 24  
29 30

**APRIL**  
6 7 8  
13 14 15  
20 21 22

1

2

3

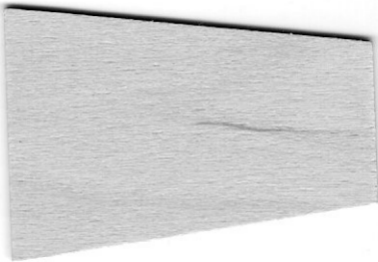

## CMR Helicopter Parts List

1. 1 ea RB92 body tube – 16” long
2. 1 ea RB90 body tube – 3” long
3. 1 ea RB90 body tube – 9.5” long (blades are cut from this tube per plans)
4. 1 ea RB74 body tube – 4” long (4 ea 1/4” holes located 3/4” from one end)
5. 2 ea CR7490 centering rings
6. 1 ea EB74 engine block
7. 3 ea 1/16” ply fins (see pattern)
8. 1 ea fine wire – 5” long – 1/32” diameter
9. 1 ea heavy wire – 5 1/4” long – 3/64” diameter
10. 2 ea glass beads (hole to accept 3/64” wire)
11. 1 ea shock cord rubber band – 3.5” long X 1/8” wide
12. 1 ea shock line – 23” long X 1/16” diameter
13. 3 ea blade rubber bands – 3/4” long X 1/16” thick
14. 1 shock cord anchor – 1” square fiberglass gauze
15. 1 ea 3/16” square balsa strip – 6” long
16. 3 ea fiberglass cloth – 3/16” wide X 1” long
17. 1 ea paper tape strip (peel and stick) – 3/8” by 3.5”
18. 1 ea launch lug – 12.5” long
19. 1 ea plastic nose cone (vacuum formed) – 2 7/8” long elliptical
20. 1 ea plastic adapter (nose cone shoulder and blade attachment). Can use a 3/8” triangular shaped strip of ply. It extends 1/2” from bottom of nose cone.