

HUSTLER



# HUSTLER

## CARRIER

### INTRODUCTION

A real work horse, the Hustler carrier rocket will carry your biological specimen or instrumentation payload to altitudes far in excess of 1,000 feet, and return it safely by parachute for many repeat launchings. The Hustler's 23 cubic inch payload capsule will handle payloads weighing up to 5 ounces and measuring up to 2½" in diameter x 6" in length.

In addition to the parts supplied, you will need the following items to assemble this kit:

Modeling knife or single edge razor blade  
White glue or modeling cement  
Paint for finishing - preferably spray type  
Fine sandpaper - Scissors - Pen or pencil

PART NO.	PART NAME
1	Body Tube
2	Nose Cone
3	Capsule Tube
4	Reduction Fin
5	Engine Mount
6	Launch Lug
7	Lug Stand-Off
8	Secure Cable
9	Shock Cord
10	Stabilizer Fin
11	Screw Eye
12	Parachute

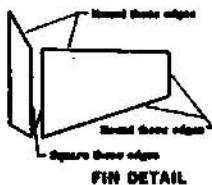
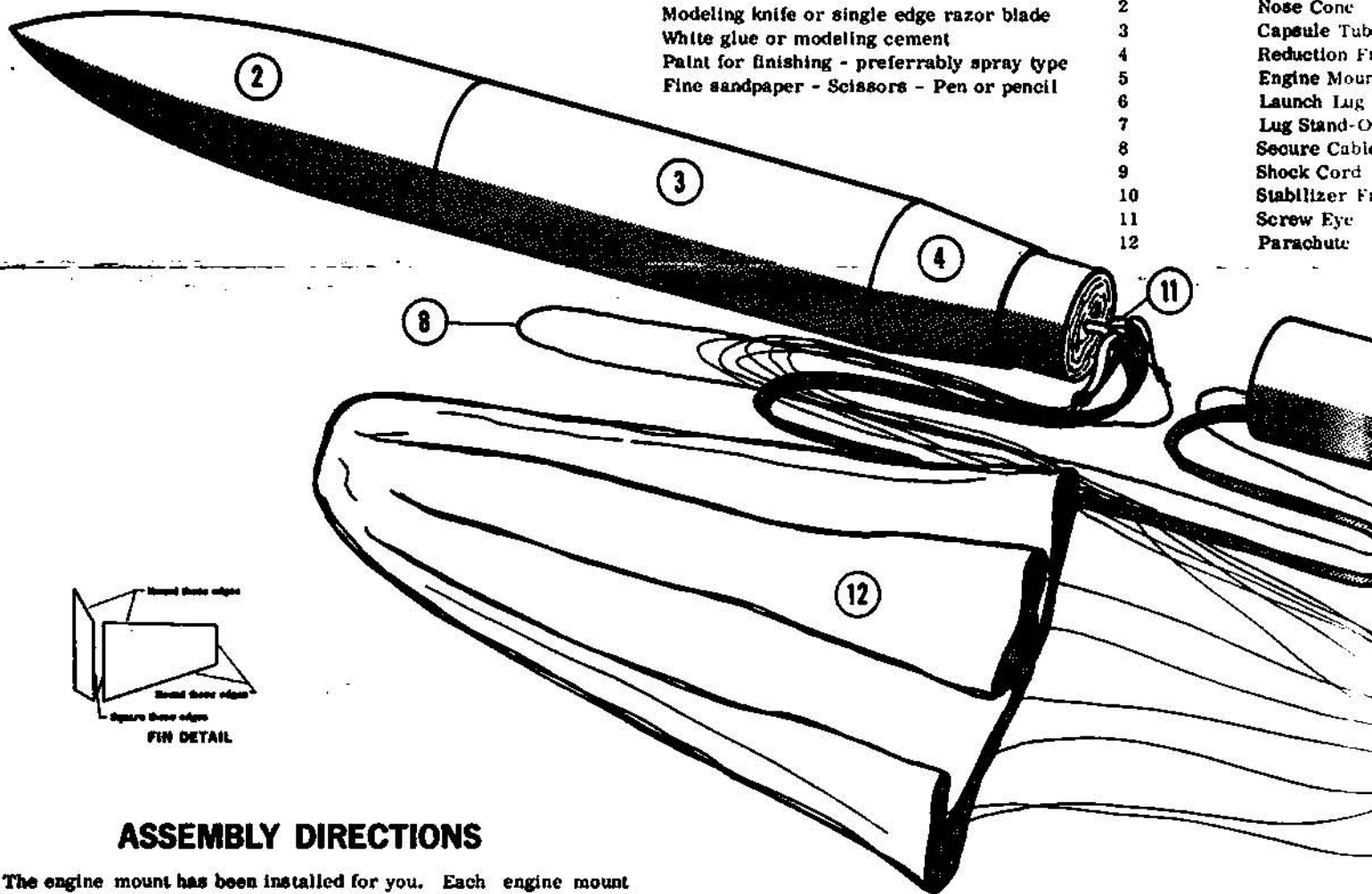

### ASSEMBLY DIRECTIONS

The engine mount has been installed for you. Each engine mount consists of two centering rings and one forward stop.

#### ATTACH STABILIZER FINS

The Hustler's composite fin design is made up of two balsa pieces. From the printed balsa sheet, cut out all indicated parts. With sandpaper, square the joining parts A and B, and also the root chord edge of part B. Glue part A to part B as shown in the fin detail illustration. This joint must be strong to prevent coming loose during high acceleration flight.

When glue joint has thoroughly dried, sand each fin as shown above. Round the leading and tip edges, and taper the trailing edge.

Cut out the enclosed Fin Positioning Guide, wrap it around the body tube near the aft end, and mark the fin locations with a pen or pencil.

Apply white glue or model cement to each fin root chord edge, one at a time, and also along the body tube where fin is to be attached. When glue has just begun to set, place fin in position along the tube. Stand the tube on its top end and allow glue to dry. With the Fin Alignment Guide, check the angle between fins before glue has completely set.

During lift-off and the subsequent accelerating period, the fins are subjected to tremendous drag pressure and buffeting. To prevent the fins from shearing off, it is necessary to reinforce them in the following manner: When the glue joint has thoroughly dried, cut out four pieces of reinforcing material about 4" square. Brush white glue or clear modeling dope onto the fin root chord and connecting body areas. Lay a piece of reinforcing material over each glued area and smooth onto the body-fin surface. Trim off any excess material and set aside to dry. After material has completely dried, sand lightly to smooth rough spots.

#### ATTACH SECURE CABLE & SHOCK CORD

Centuri's unique shock cord secure cable has been installed for you. One end of the fine steel cable is firmly anchored to the forward engine mount. The opposite end is anchored to the capsule screw eye.

# NEW HUSTLER ROCKET

NAME  
tube  
Fitting  
units  
G  
Off  
ble  
d  
Fins

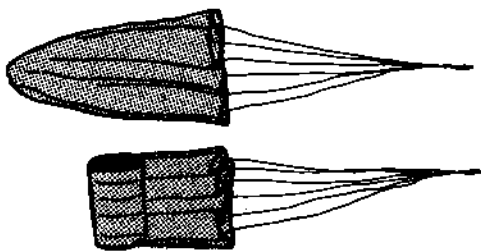

PACKING CHUTE IN ROCKET

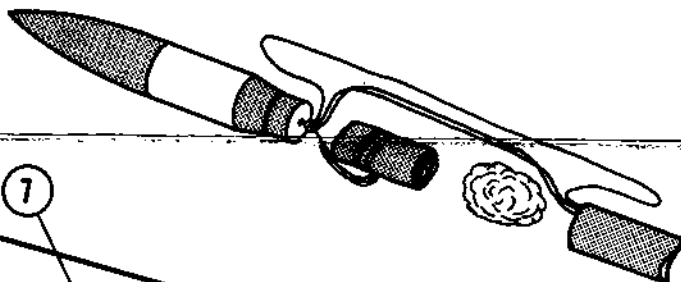

## ASSEMBLY DRAWINGS

Thread the screw eye into the capsule base as shown. Unscrew the eye, squirt glue into the resulting hole, and thread the eye back into place. This glueing will keep the eye from pulling out during recovery.

The elastic shock cord absorbs the shock created by the opening parachute while the steel secure cable secures the rocket to the recovery parachute.

### ATTACH PARACHUTE & LAUNCH LUG

Snap the parachute shroud clip onto the capsule screw eye. Glue each lug stand-off about 8" apart, in the position shown. To assure a straight lift-off from the launch rod, it is important that the lug be lined up with the body tube. Before the glue has completely set, sight down the rocket, like a rifle sight, and line up the lug stand-offs. Glue lugs along stand-off edges, and before this glueing has completely set, insert the enclosed 3/16" dowell through both lugs and allign with the axis of body tube.

### RIG PARACHUTE

Just prior to launching, fold and pack the parachute as shown below:

Wrap the chute shrouds around the folded canopy. Insert a piece of flameproof cotton wadding, about the size of a large egg, into the body tube first. Next, insert shock cord and secure cable, followed by the folded parachute and the nose cone.

### ASSEMBLE PAYLOAD CONE

The payload capsule has been pre-assembled for you. It is advisable however, to glue the reduction fitting to the capsule tube so that the capsule does not open during recovery. Likewise, the nose cone should be made to fit tightly by wrapping a layer or two of cellophane tape around its base until a friction tight fit is obtained.

### FINISHING

To obtain maximum altitude flights, all model rockets should be filled in with several coats of balsa filler. Sand smooth between applications. The body tube does not require this treatment. Finish entire model with a lightweight paint such as spray type dope or laquerized enamel. To aid in tracking, use bright colors such as white, yellow, orange, or red. Flourescent colors are quite easy to spot at high altitudes.

### PREPARING THE PAYLOAD

The Hustler is capable of carrying a maximum payload weight of 5 ounces. Fragile payloads should be packed in cotton or foam rubber.

### LAUNCHING

The Hustler can be powered by any of the following standard rocket engines:

F 11-3

F 15-4

F 25-6

Complete mounting and ignition instructions are supplied with these engines. Read the instructions carefully before operating.

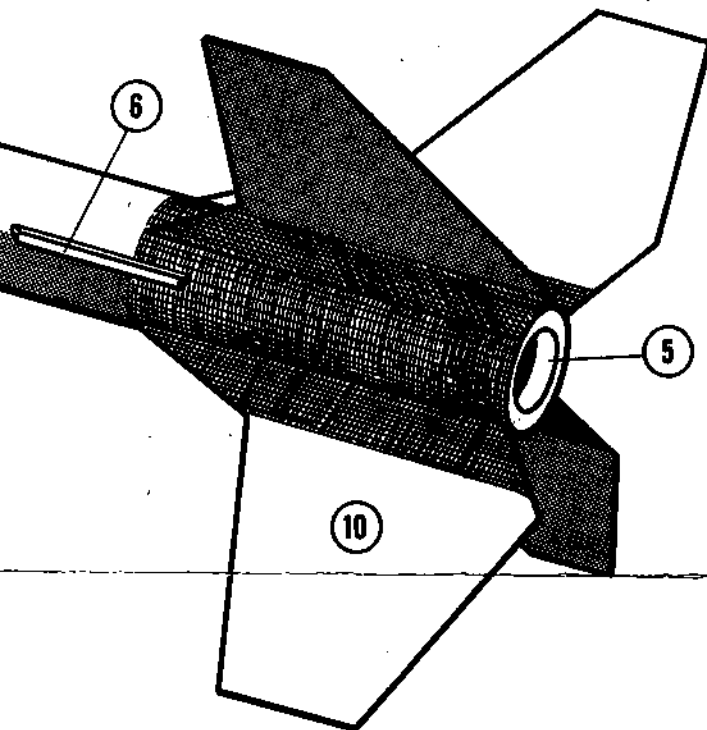

Launch the Hustler from a 3/16" diameter x 36" long launching rod mounted firmly in a sturdy base block or stand, such as those shown in Centuri's catalog. Select a clear, unobstructed launch site away from houses, highways, and trees. The Hustler should be launched from the center of an open field measuring at least 800 feet on a side.

Avoid launching in windy or overcast weather, as recovery under these conditions will be difficult if not impossible. Always give a short countdown before launching to alert spectators and trackers. Do not launch from a backyard or in populated areas.

For further information regarding rocket kits, engines, ignition devices, launching accessories, or replacement parts write to:

CENTURI ENGINEERING COMPANY

P. O. Box 1988

Phoenix, Arizona 85001

## FIN POSITIONING GUIDE

Wrap around body tube-----tape end flap  
closed--mark fin locations-- and remove.

**CENTURI ENGINEERING COMPANY**  
Phoenix, Arizona

## FIN ALIGNMENT GUIDE

For 4-fin arrangement  
on 1.75" I. D. body tube.

### FIN POSITIONING GUIDE

Wrap around body tube-----tape end flap closed--mark fin locations--and remove.

**CENTURI ENGINEERING COMPANY**

Phoenix, Arizona

### FIN ALIGNMENT GUIDE

For 4-fin arrangement on 1.25" I.D. body tube.

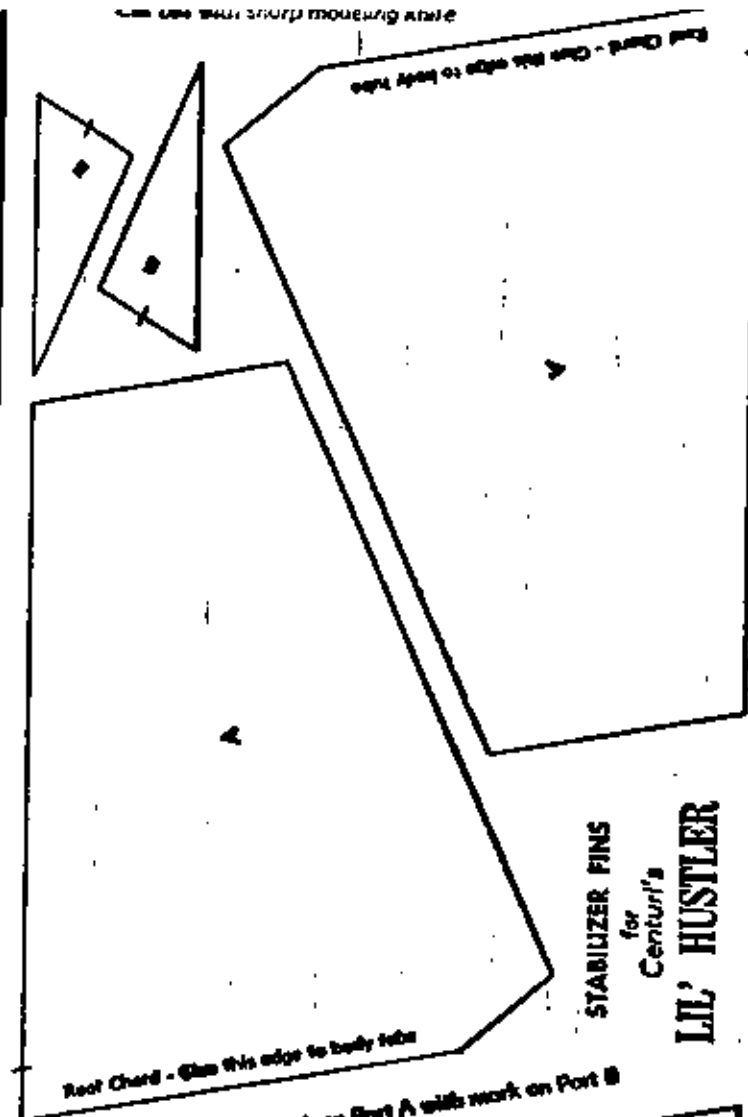
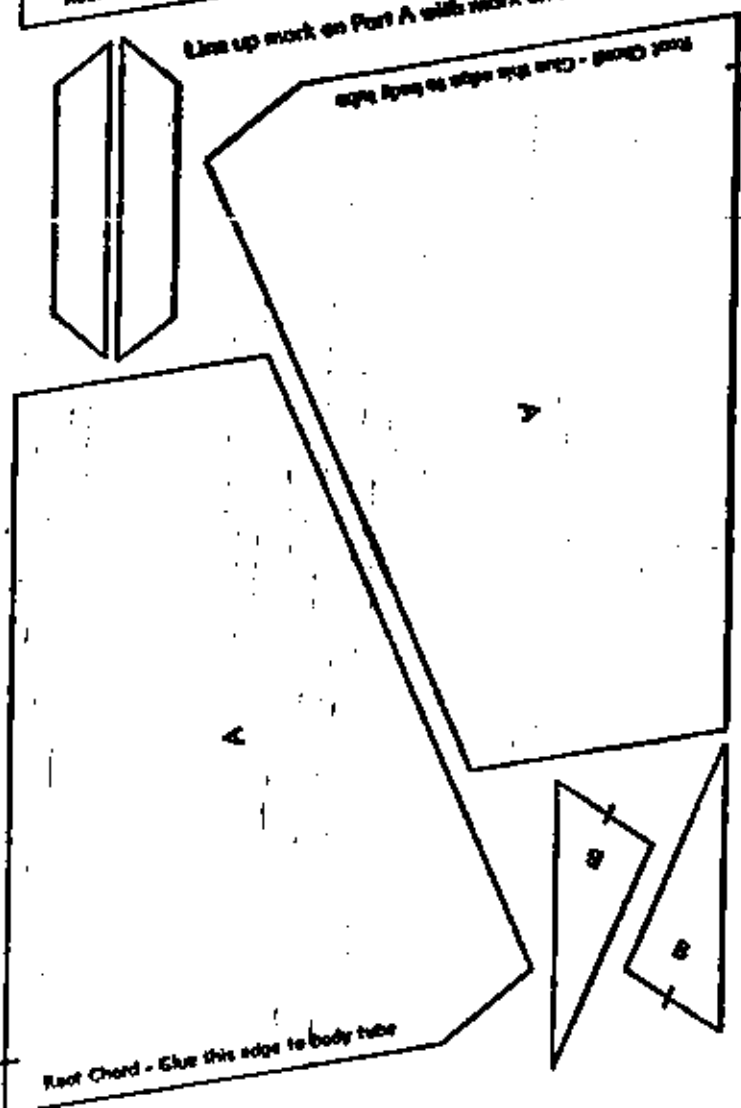

STABILIZER FINS  
for  
Centuri's  
**LIL' HUSTLER**

© 1974 Centuri Engineering Company

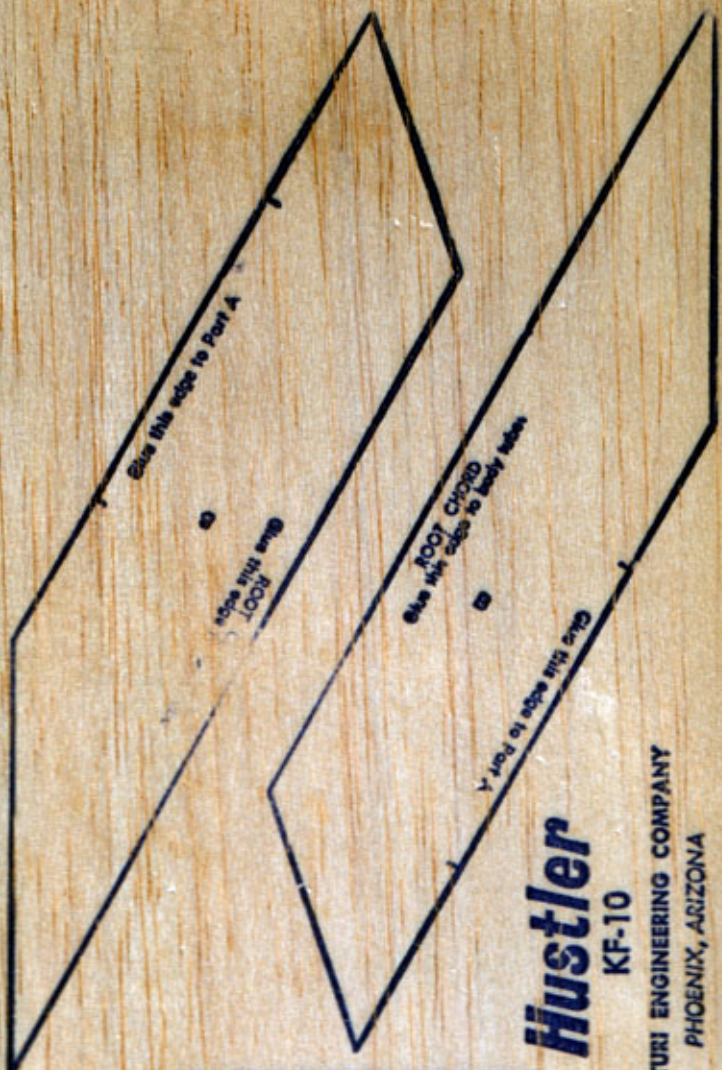

**Hustler**

**KF-10**

**CENTURI ENGINEERING COMPANY**  
**PHOENIX, ARIZONA**

## Cloning the Hustler (Centuri KF-10)

---

Stefan Jones

September 30, 2003: This is an updated version of an earlier document. I've since completed and flown my "Hustler" clone.

Here it is on the day of its first (at at this time, only) flight:

[http://www.io.com/~stefanj/hustler\\_on\\_the\\_roof.jpg](http://www.io.com/~stefanj/hustler_on_the_roof.jpg)

[http://www.io.com/~stefanj/posed\\_with\\_hustler.jpg](http://www.io.com/~stefanj/posed_with_hustler.jpg)

I flew it with an Aerotech RMS 40/120 case with a F22J-5 reload. The flight was as good as they come. Once the supply of reload kits loosens up I'll fly it with a larger motor.

I've also built and flown a clone of the Aero-Dart, whose construction is virtually the same as the Hustler.

<http://www.io.com/~stefanj/aerodart.jpg>

---

The "Hustler" was one of Centuri's early high power kits. It is a payload model, with an enlarged payload section that the catalog copy suggested could be used for cameras, biological specimens, electronic payloads and the like. It has the rakish look favored by Centuri in the late 60s. It's not a big model by today's standards, and doesn't use any advanced techniques (e.g., through the wall construction). But I like its looks and thought it was worthy of cloning.

The model was introduced around 1965, and was designed to fly on the black powder F motors (Hercules, later MiniMax) that Centuri sold through 1971. The Hercules last appeared in the 1971 catalog; the recommended motors there included the new Enerjet composite motors.

The Hustler also appears in a color photo on the inside back cover of the 1969 and 1971 catalogs. It's visible behind Leroy Piester. The model has a very snazzy black, orange, and white paint-job, with the usual odd Centuri roll-bar.

### TUBES

The Hustler used the old Centuri 1.75" ID and 2.25" ID heavy-duty tubes for the body and payload section, respectively. The catalog lists the wall thickness as .045", making the outside diameters 1.84" and 2.34" respectively. The reported lengths are 22" and 8" respectively. Sean Lannan, who has an original kit, notes that the body tube is a bit longer (22.1").

The Aerotech "1.9" tube (OD 1.88") is a close match for the ST-175 body tube. Totally Tubular sells this tube, along with coupler stock.

For the payload section, you might find a piece of FSI's "RT-22" tubing, which is an exact match dimensionally. Firefox Industries sells a tube that is supposedly of these dimensions, as well as a body tube and coupler and nose cone. I was fortunate enough to get a length of the original tubing. (Thanks Len!)

A slightly "downscale" and oddly-proportioned Hustler could be made from a BT-60 body and a BT-70 payload tube. Estes made a balsa adapter to join these tubes (TA-6070), and BMS stocks the BT-70AJ nose cone. I am making two of these clones. To make the cones and transitions more proportional, I extended the shoulders with a bit of BT-70 coupler. This let me fill in (using balsa putty) 1/4" of the cone and transitions' balsa shoulders, effectively lengthening the pieces.

#### ENGINE MOUNT

The Hustler had a mount for a 1.125" diameter x 7.75" long MiniMax engine.

In early versions, the mount consisted of two hardwood centering rings and a "stop." There was no motor tube! I don't know what the stop consisted of; perhaps a centering ring with a smaller-diameter center hole.

Later versions of the Hustler (and probably other MiniMax kits) had a motor mount very similar to a modern 29mm motor mount. This mount had a 1" long black "fish paper" thrust ring, and a 8" long mount tube.

The centering rings were 3/4" thick balsa, at least in some versions. To judge from my Aero-Dart (circa 1969), some kits thick wound-fibre rings. My full-scale Hustler clones have balsa centering rings made from a stack of three 1/4" balsa rings made by BMS.

The catalog copy states that the Hustler came with adapter for the MiniMax F motors. This was, apparently, a length of black fish paper tubing.

There was no engine hook. Motors were probably friction-fitted to prevent ejection. This has worked fine in my flights to date.

#### FINS

The stock Hustler uses 3/16" balsa fins. The fin patterns were printed, two pieces per fin, directly on the balsa stock. (If the fin stock included with my "Aero-Dart" is typical of MiniMax kits, then the stock is VERY hard, high-quality C-grain balsa.)

A scan of an original sheet was kindly provided by Sean Lenann, who notes that the root edge on a properly scaled print-out should be 3.8" long. (The sheets are 4" wide.)

In the original kit, the fins were glued directly to the body tube; fabric ("Silray") reinforcements were then glued or doped over the fin/tube joints.

On my clone, I roughed up the glossy body tube surface a bit and used "fin rivets." I decided to use lightweight fiberglass for reinforcements, and added strips of fiberglass to the leading and trailing edges. I used 2 Hour epoxy to laminate the fiberglass to the balsa.

#### NOSE CONE

The nose cone is balsa, overall length 7.85" with a 6.9" visible section.

If my Aero-Dart nose is to judge, the balsa used was very hard and dense.



A cone for the payload section is available from Firefox Industries, but there's no guarantee how close a match it is to the original shape. I turned my own cones for the payload tube, using balsa stock from BMS.

#### TRANSITION

According to the catalog, the balsa transition section had a 2.1" long visible section. I measured an actual example (Thanks, Sean!) and it was almost exactly 2 3/8" long.

I turned the transitions for my clones from 3" balsa stock. Because the original shoulder was rather short, I added 1.5" of coupler stock to the narrow end. This makes for a much more secure fit, with less of a chance of torquing.

#### LAUNCH LUGS

Centuri used glossy fibre 3/16" launch lugs for its high-power kits. I did some guesstimation and determined that the Aero-Dart had 2" long lugs. The Hustler probably used these as well.

Some Centuri catalogs offered aluminum 3/16" lugs. Early Hustlers may have used these.

The lugs were mounted on balsa stand-offs, to allow the launch rod to clear the payload section. I have not seen patterns for these, but based on the illustrations in the plan, they're probably flattish trapezoids, with a height of 1/2", top 2" wide, base 3" long.

#### RECOVERY SYSTEM

The catalog notes that the Hustler used a 24" hemispherical silk parachute with red, white, and black panels. For my clone, I used a 21" parachute made from the canopy of a toy umbrella.

The original kit came with the motor mount and shock cord installed. If it's anything like my Aero-Dart, the Hustler's shock cord consists of a heavy duty black elastic strip (1/4" or so) plus a braided wire "check cord." These run in parallel; the check cord is a bit longer than the elastic.

By modern standards, the harness installed in my Aero-Dart is WAY too short for comfort. It almost guarantees destructive "snap back."

For both my Aero-Dart and Hustler clones, I used a 12" kevlar anchor cord and a three-yard piece of black 1/4" elastic. I tied the anchor cord to the motor mount, passed it through a notch on the inner surface of the centering ring, and added a barrel swivel. After the model was finished, I shook the model until the cord and swivel fell through the motor mount tube; I tied the elastic cord to the swivel and fed it back through the mount tube and out of the front for attachment to a screw-eye on the transition section.

#### PAINT SCHEMES

A variety of paint schemes are shown in the catalogs. None appear to be official. I chose the scheme shown in the only actual photos of the Hustler:

- \* White main body tube
- \* Red or orange payload tube

- \* Two black fins, two white fins
- \* Black nose cone and transition

The picture shows a roll bar, but with not enough detail to determine the exact dimensions. I made a temporary roll bar with 3/4" PVC tape. The photo model also shows a black Centuri logo.

#### OTHER STUFF

According to accepted history Centuri's big BP motors used tooling and designs made by Coaster, a hoary pioneer of large scale rocketry. However, there are clues that Leroy Piester made large BP motors very early on; one Centuri newsletter states that he made "MiniMax" motors in the mid 1950s!

In any case, Centuri offered an F motor (F11-3, old rating system) in its 1964 catalog. The 1965 catalog offered end-burning Atlas and port-burning Hercules motors, in D - F classes. Both were shown as having 1.0625" casings.

The Mini-Max name was in use by '67 at least (there's no '66 catalog to refer to). Case diameter was shown as 1.125".

The motor offerings changed almost yearly until Mini-Max disappeared in 1971. There tended to be several low-impulse motors (long-burning motors for the "Jaguar", "Scorpion" and "Explorer" kits) and one or two high-impulse motors (F100-like motors, for the "Explorer," "Lil' Hustler", "Aero-Dart" and "Hustler"). For a few years, D, E, and F motors were all offered.

It must have been hell keeping up with the changes. One year Centuri offered a "E7" (incidentally, almost identical to the Estes E9 except for the heavier casing); the next two, an "E15," with much higher total impulse.

I've heard, from several anecdotal sources, that Mini-Max motors were horribly unreliable. Al Andrade, of AAA Model Aviation Fuels, told me that Irv Waite (RDC, Enerjet) determined that part of the problem was the depth sensor on the Mini-Max motor press. The machine pounded three motors at once, but the sensor only checked the depth of the ram in one of the cylinders. When the ram reached the proper depth, the hydraulic pressure to all three cylinders was cut off. This meant that the other two cylinders could have improperly pressed grains. Waite's suggested improvements greatly increased the reliability of the Mini-Max motors . . . of course, Waite was also to introduce the Enerjet motors that pretty much doomed the BP line. So it goes.

Mini-Max motors apparently used an igniter that consisted of a fuse-like material and some nichrome. The motors came wrapped in a glossy white wrapper with colorful printing. I don't know if this had to be removed for mounting. Since the motors were friction-fitted, this might have been necessary.

If you find yourself chafing at current DOT restrictions, consider: Mini-Max and Enerjet motors were totally unmailable. You had to have them shipped, freight collect, by Railway Express, a long-defunct shipping firm. My 1971 Centuri catalog provides estimated shipping to the East Coast starting at \$5.00. (To be fair, this would have covered up to a dozen big motors.) This was a big chunk of money at the time, and Railway Express didn't deliver everywhere. I've heard that the company delivered to the door by truck, dispelling the romantic image of waiting at a depot and getting handed your package from the door of a boxcar.

A clone Hustler should fly well on a variety of composite motors. However, for full authenticity you should tap into the diminishing supply of FSI F100 or Rocketflite F101 or F50 motors, which are probably a close match for the MiniMax F97. A CATO that blows the model to smithereens could be seen as a recreation of an authentic MiniMax-flying experience.

END

Interesting Correspondence

Re: [OldRockets] MiniMax Hustler: Payload tube length?  
Date: Mon, 15 Jul 2002 6:38:09 PM Eastern Standard Time  
From: Sean Lannan <selannan@yahoo.com>  
To: OldRockets@yahoogroups.com  
Reply-To: OldRockets@yahoogroups.com  
Sent from the Internet (Details)

Sorry, I should have been more specific. The total length [of the nose cone] w/shoulder is ~7.85" [with a 6.9" visible section].

The Hustler's length (the one I have, anyway) works out to: main tube 22.1" + transition 2.5" + payload tube 8" + nose cone 6.9" + 1" for the fin tips = 40.5. This isn't the only kit Centuri gave the wrong specs for. Makes them tough to clone with out a kit to measure.

I'll send you the pattern in another email. I'll be sending the plans and templates to the YORS plan site as soon as I get around to splicing The plans together.

Sean