

SLAT/s

Introduction

The SLAT/s is loosely based on a Supersonic Low-Altitude Target drone designed by Teledyne Ryan Aeronautical in the mid-1980s. The U.S. Navy wanted an unmanned aerial vehicle to test ship defenses by simulating an anti-ship missile. The SLAT proposed by Teledyne Ryan was to be powered by a ramjet with integral solid-propellant rocket booster; it would fly horizontally at Mach 2.5 a mere 30 feet above the sea. Unfortunately, the proposal was ultimately rejected in favor of a competing design.

LawnDart Rocketry's SLAT/s model features a simulated ramjet (which doubles as the launch lug) and an unusual fin configuration. Construction is a bit different from run-of-the-mill rockets, so read through the following instructions before beginning to build.

SLAT/s

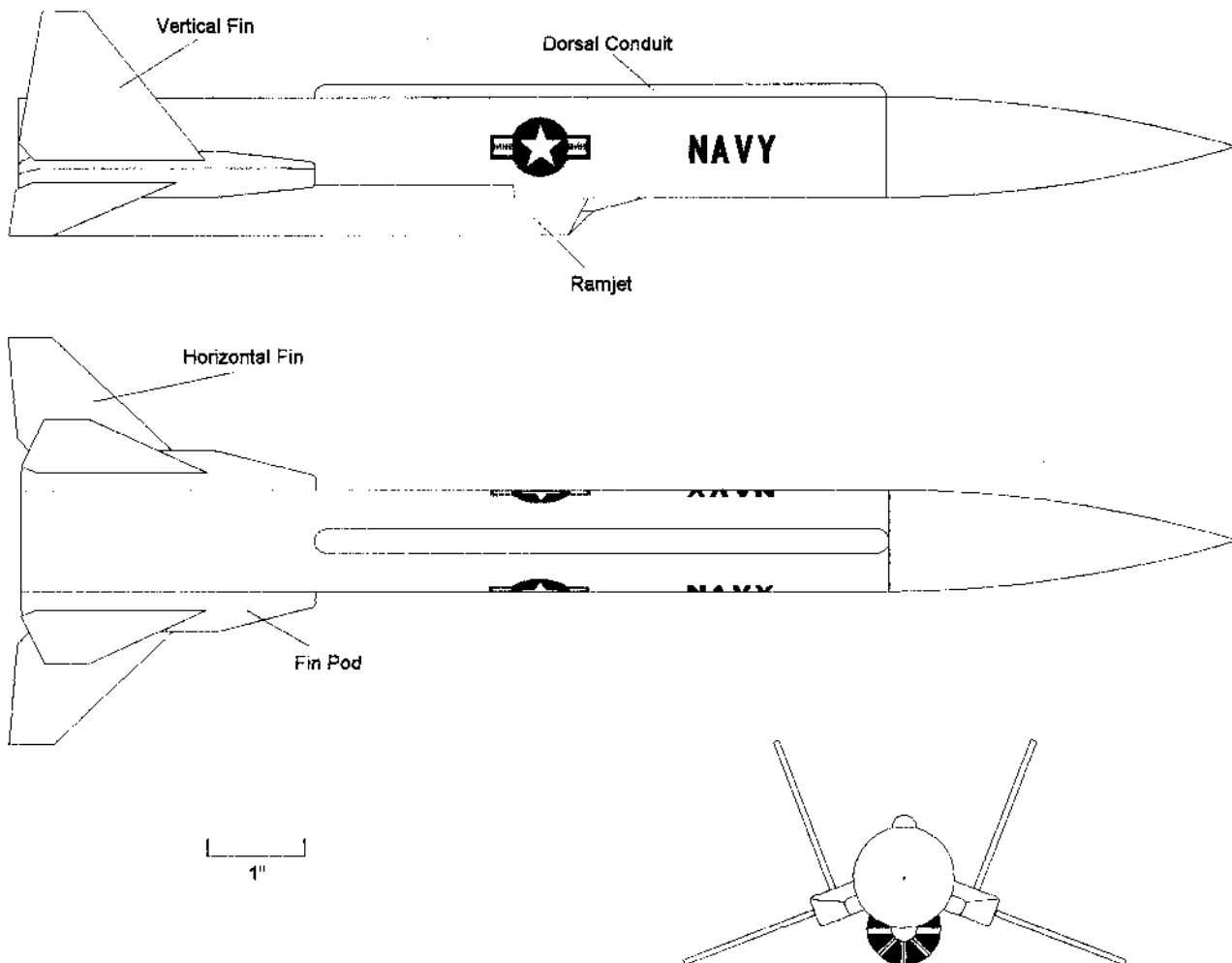

Parts List

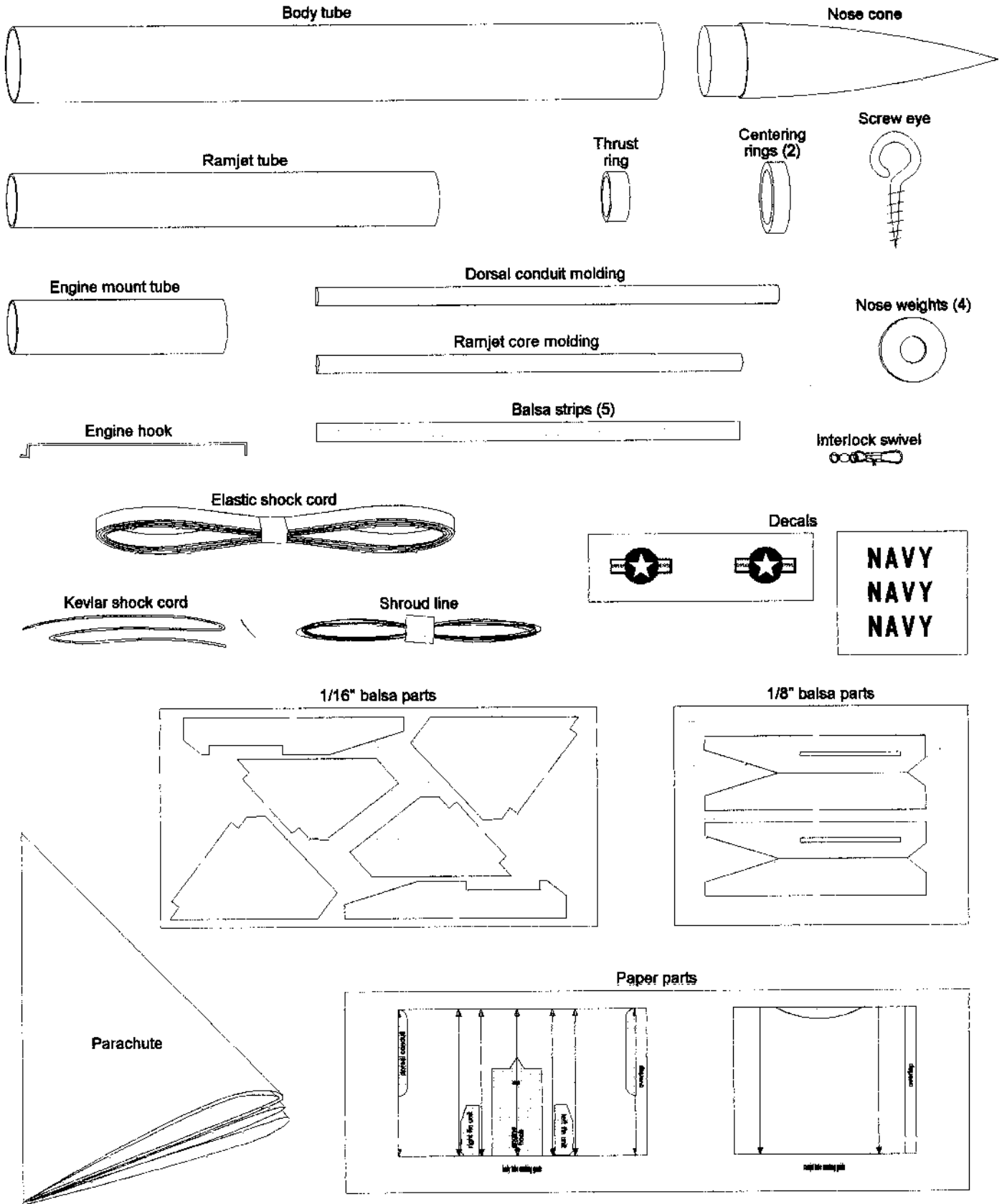

Engine Mount

1. Engine hook and thrust ring

Poke a small hole into the engine mount tube $\frac{1}{8}$ " from one end. Insert the forward end of the engine hook. Apply a ring of glue inside the tube where the thrust ring will go.

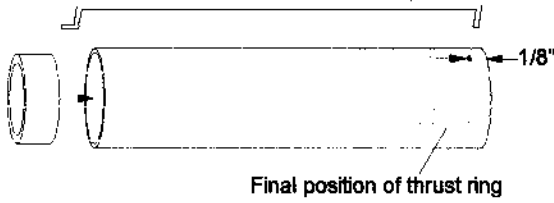

Use an expended motor casing to slide the thrust ring up against the end of the engine hook.

2. Shock cord anchor

Tie one end of the Kevlar line around the engine mount.

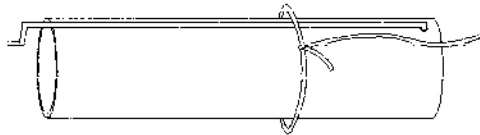

3. Centering rings

Cut a small notch on the inside of both centering rings, just big enough to allow the engine hook to pass.

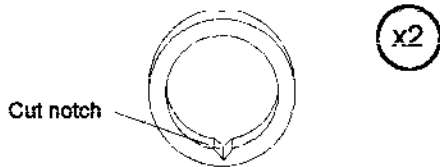

Slide one centering ring onto the rear of the engine mount, aligning the notch over the engine hook. Glue it into position $\frac{3}{4}$ " from the rear. Glue the other centering ring $\frac{1}{8}$ " from the front end, allowing both the engine hook and the Kevlar line to pass through the notch.

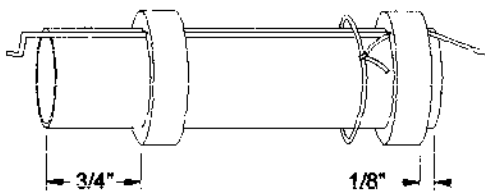

Apply a drop of glue where the front of the engine hook meets the thrust ring inside the engine mount to keep the engine hook properly lined up.

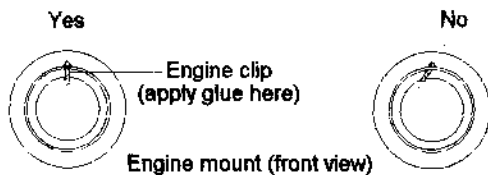

4. Installation

Tie a loop in the Kevlar so that the distance between the rear of the engine mount to the farthest point of the loop is 8". Cut off any excess.

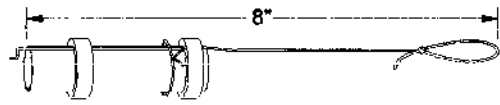

When the glue on the centering rings has set, apply glue to the inside of the body tube $\frac{3}{4}$ " in. Thread the Kevlar line through the engine mount tube, then slide the engine mount into the body.

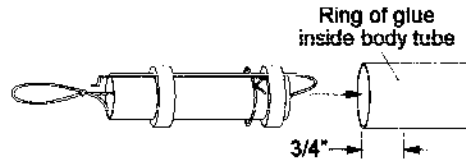

Align the ends of the engine mount and the body.

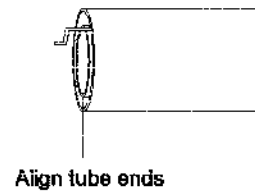

Set aside to dry.

Ramjet

1. Core

Take the $6\frac{1}{4}$ "-long half-round molding (the longer of the two) and wrap a couple of layers of masking tape near one end, leaving $\frac{1}{2}$ " exposed. Form the exposed portion into a half-cone by careful carving with a hobby knife followed by filing or sanding. The tape should create a stable edge.

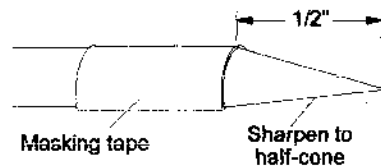

Remove tape when done.

2. Vanes

Take two of the balsa strips and on each, sand a shallow bevel at one end. If you intend to apply balsa filler or sealer, you can incorporate it into the sanding process.

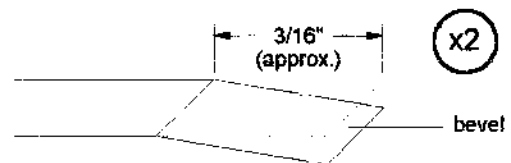

Lay the core molding on a flat surface and glue on the two strips, aligning their rear edges with the end of the core.

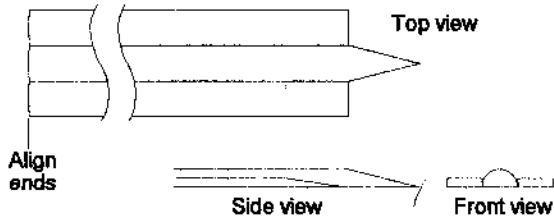

3. Vanes (cont'd)

Take one balsa strip and cut one end using the cutting guide below.

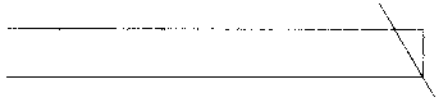

Bevel both sides of the cut end.

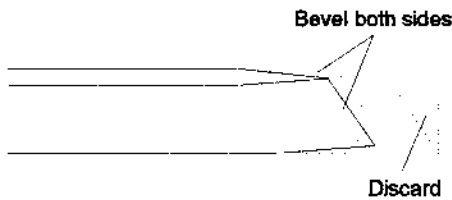

Glue this strip to the core as shown below. In this and the following step, careful "eyeball" measurements should produce perfectly satisfactory results.

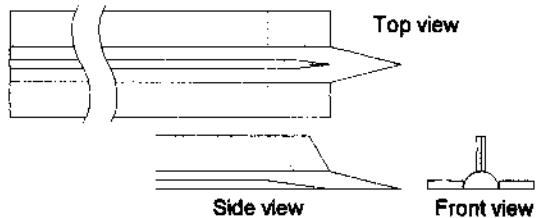

4. Vanes (final)

For each of the two remaining balsa strips, cut one end using the cutting guide below and bevel both sides of the cut end. This is similar to the previous step, but the cutting angle is slightly different.

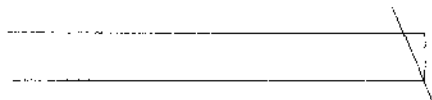

Glue each strip to the core at a 45° angle between a horizontal and vertical vane.

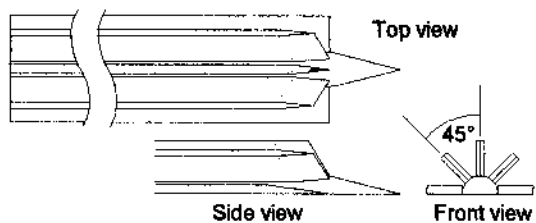

5. Cut tube

From the paper parts sheet, cut out the ramjet tube marking guide. Wrap it around the ramjet tube and tape it together. Align the front of the guide with the end of the tube and tape it in place. Mark the tube at the arrowheads on the guide.

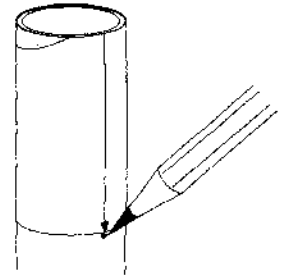

Temporarily insert an expended engine casing into the tube to provide support. With a sharp hobby knife, carefully cut out the shaded portion of the arc, cutting through both the guide and the

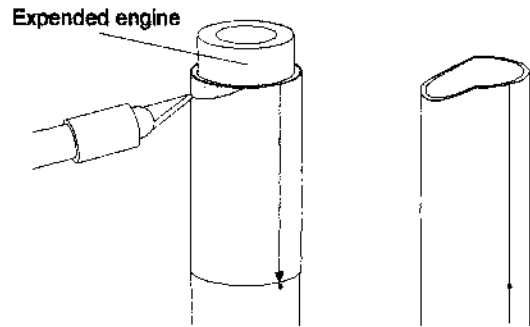

tube underneath.

Remove the guide. Place the tube in a door frame and draw straight lines through the marks made previously.

Soak some thin cyanoacrylate ("super glue") into the cut edge. Once it dries, the edge can be sanded smooth.

Place the tube in a door frame as before, but this time cut the tube along the lines. This will produce two pieces. The larger piece, with the cutout at the front, is the ramjet casing; the smaller piece may be discarded.

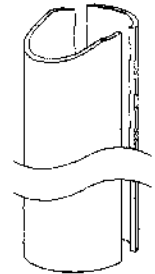

6. Assemble ramjet

Test fit the core assembly in the casing. The positioning is a bit tricky because the ramjet casing, no longer a tube, has a tendency to twist. Once the core is nicely centered, mark its position on the inside of the casing.

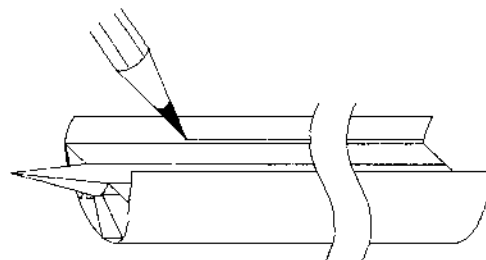

Remove the core. Cut out 3/4"-long rectangles from the casing using the lines just drawn.

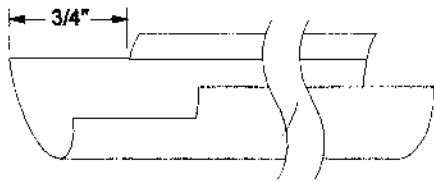

Put the core back into the casing and glue it in place.

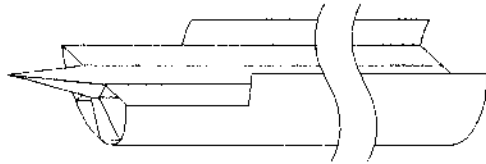

Fin Units

1. Detach parts

Free the laser-cut parts by using a hobby knife to slice through the tabs holding them to the sheets. There will be four 1/8"-thick parts and six 1/16"-thick parts. Note the names of the parts in the following diagram (there are two of each part).

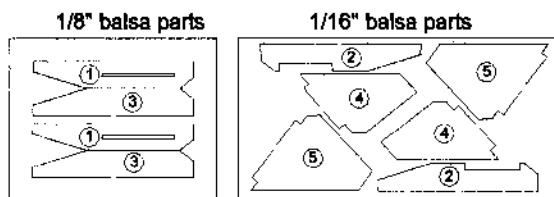

- | | |
|-------------------|-------------------|
| 1. Fin pod top | 4. Vertical fin |
| 2. Fin pod middle | 5. Horizontal fin |
| 3. Fin pod bottom | |

2. Fin pod assembly

Place the two fin pod bottoms onto a flat surface, orienting them so that one is a left part and the other is a right part. On top of each, glue a fin pod middle part, suitably oriented. Remove any excess glue from the cutout region. Top each stack with a fin pod top piece. Remove any excess glue from the slots.

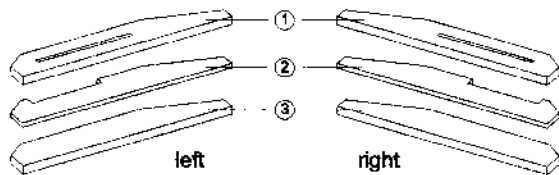

When the glue has set, sand the sides of the stacks flat.

3. Bevel

Take the two fin pod assemblies and wrap a couple of layers of masking tape around them as shown here.

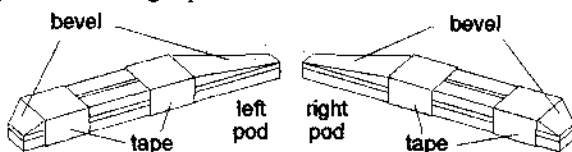

Bevel the forward and aft portions of the top layer only, using the tape to mark the bevel edge. Remove tape when done.

4. Round-over edges

Round all the edges—except those on the side that will be attached to the body—to a radius of approximately 1/32".

You may also want to sand an airfoil into the fins.

Depending on your finishing technique, you might want to apply balsa filler or sealer before attaching the fins; if you do so, take care not to get anything on the fin tabs or in the slots that might compromise glue joint strength.

5. Attach fins

Glue the vertical and horizontal fins into the appropriate slots on the fin pods.

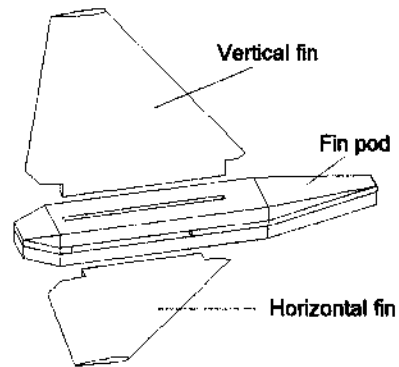

Dorsal Conduit

1. Round ends

Round both ends of the 5 3/4"-long half-round molding.

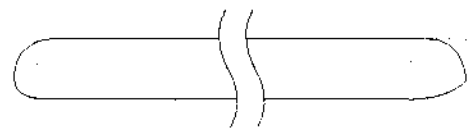

Main Assembly

1. Mark body tube

Cut out the body tube marking guide from the paper parts sheet. Wrap it around the body tube (lining up the engine hook with the point indicated on the guide) and tape it together. Mark the tube at the arrowheads and remove the guide. Draw lines through the marks, parallel to the tube.

2. Attach ramjet

Attach the ramjet assembly to the ventral side of the body. The rear of the ramjet should be aligned with the rear of the body. Add glue fillets to smooth the ramjet-body junction.

3. Attach dorsal conduit

Attach the conduit to the dorsal side of the body, aligning the front of the molding with the front of the body tube.

4. Attach fin units

Attach the fin units to the body between the appropriate pairs of lines. Use a double-glue joint for maximum strength. If the rocket is placed on a flat surface, the horizontal fin tips should touch the surface.

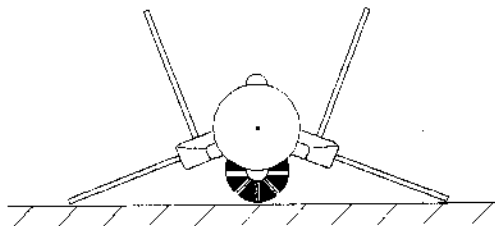

5. Fillets

Fillet the gaps between the body tube and the flat surfaces of the fin units and the dorsal conduit.

6. Nose cone

Test the nose cone for fit; sand if necessary.

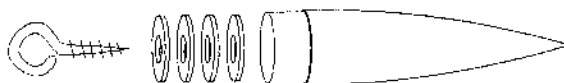

Screw the screw eye into the base of the nose cone. Remove, squirt some glue into the hole, and replace the screw eye through the four nose-weight washers.

Recovery System

1. Parachute assembly

The supplied parachute is a pre-cut octagon of mylar. Cut the supplied shroud line into four equal lengths. Attach the ends of the lines to the corners of the parachute using squares of common household clear adhesive tape.

2. Shock cord

Pull the Kevlar line out the rear end of the engine mount and tie one end of the elastic shock cord to the loop. Thread the elastic through the engine mount and out the front of the body tube. The Kevlar line should not reach the lip of the body tube (otherwise it might cut the tube at deployment).

Tie the free end of the elastic to the screw eye. Attach the interlock swivel to the screw eye.

Finishing

1. Painting

Prepare the rocket for painting by ensuring that body tube seams are filled and wood surfaces are sealed. Paint the rocket orange overall.

2. Decals

There are two sets of decals provided, one in color (stars and bars), the other just black ("NAVY"). Both are water-transferable decals. Cut out each decal separately. Soak in a small amount of water until the decal slides easily off its backing onto the model. Note: these decals are thin and will fold over on themselves unless you are very careful. An extra "NAVY" decal is provided so you can practice.

Flight Preparation

1. Engine selection

Recommended engines are A8-3 (first flight), B6-4, and C6-5.

2. Recovery system

Fold the parachute, wrapping the shroud lines around it. Insert flameproof recovery wadding in the body tube, followed by the elastic shock cord and then the parachute. Install the nose cone.

3. Balancing

Proper location of the CG (Center of Gravity) is essential for stable flight. With the rocket in flight-ready condition (live engine installed), find the rocket's balance point. It should balance at least 4 1/2" from the rear lip of the body tube; add nose weight if necessary.

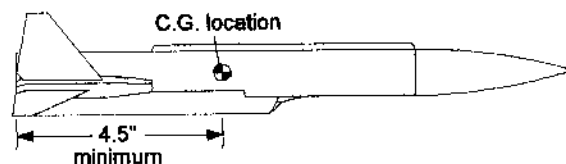

4. Place on launch pad

Install an igniter in the engine according to the manufacturer's directions. Place the rocket on the launch pad, sliding the launch rod through the ramjet.

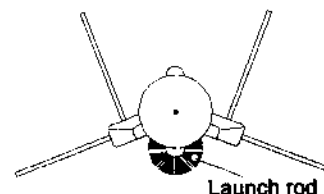

LawnDart Rocketry shall not be held responsible for injury or damage caused by the storage, handling, or use of this product.

LawnDart Rocketry • 879 Westfield Row • Acworth, GA 30102-6900

www.fly.to/LawnDartRocketry



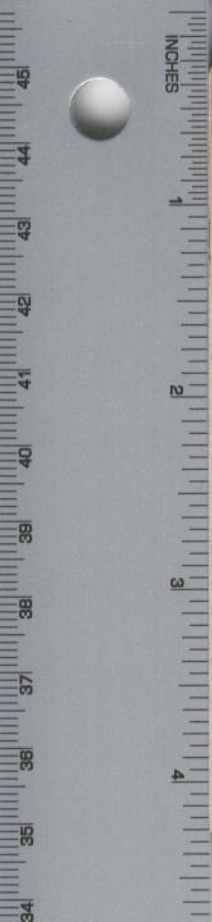

body tube marking guide

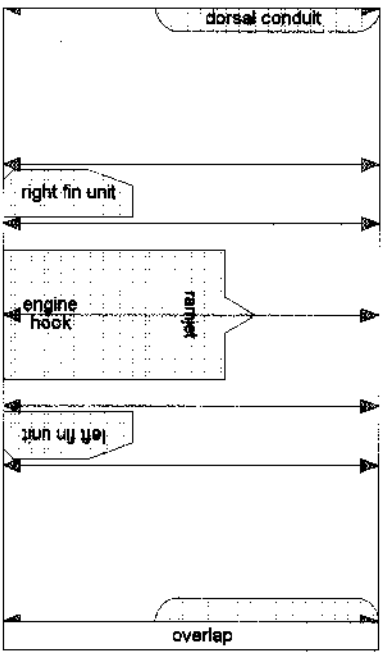

ramjet tube marking guide

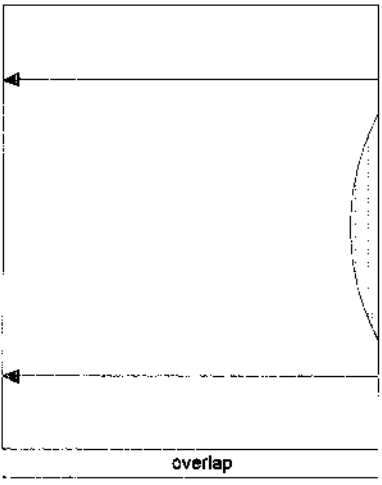



SLAT/s

Parts List

Qty	Description
1	Body Tube ST-10 8.75"
1	Nose Cone Balsa 3.625" Ogive
1	Ramjet Tube ST-7 5.75"
1	Thrust Ring
2	Centering Rings
1	Screw Eye 0.75"
1	Engine Mount Tube ST-7 2.75"
1	Dorsal Conduit Molding 0.25" x 6.25" Half Round Balsa Strip
1	Ramjet Core Molding 0.25" x 5.75" Half Round Balsa Strip
4	Nose Weights .375 Washers
1	Engine Hook
5	Balsa Strips 0.0625 x 0.25 x 5.75
1	Elastic Shock Cord 36"
1	Kevlar Shock Cord 16.5"
1	Decals
1	Interlock Swivel
1	Shroud Line
1	Parachute 12"
	Paper Parts
	Balsa Parts