



the
GRUMPY DOG II

designed by PHIL ENGELAUF 21317

If you're looking for a good rocket to impress your friends with, you'll find it in the Grumpy Dog II. If the RSO gets over his initial shock and tries weighing it, he will find that it comes to a fearful thirteen ounces, with engines and before painting. It flies beautifully and is sure to be the hottest thing out at your next launch.

I first designed the Grumpy Dog I as a demonstration rocket to be used at our club's recent membership drive. Two test flights showed that it had excellent flight characteristics. I launched it successfully three more times at demonstration launches, then BANG, it turned grumpy (hence the name). I just couldn't get the second stage to ignite. Two consecutive misfires convinced me that I had to make a few changes. Adding the gas channel to the booster and making a few other modifications made all the difference in the world. Staging on the Grumpy Dog II has been one hundred percent reliable.

The Grumpy Dog II will serve as an excellent demonstration rocket with a D12-0 - D12-5 engine combination. The best ejection delay varies with the particular rocket, but the three or five second delays work just about the same if the rocket weighs in at about fifteen ounces (with engines and paint).

CONSTRUCTION

Start off by joining the four pieces of BT-60 with the JT-60C tube couplers. To ensure accurate alignment, roll the completed assembly on a flat surface. Remember, this rocket is eight feet long and any misalignment will cause flexing, which will have a dynamic effect on the flight performance.

Next, cut one of the BT-70's so that you have a 4-1/2 inch booster body, a 2 inch ring, and 11 inches of tube left over. Cut a 1/8 inch strip out of the 2-inch ring and glue it into the booster tube so that one inch of tubing protrudes from the booster tube, acting as a tube coupler.

Next assemble the engine mount as shown in the drawing. The centering rings and slats should be firmly filleted to ensure strength. Cut a BT-20 1-1/2 inches long, and glue the AR-2050 rings flush with each of its ends. Again, fillet heavily. When dry, insert this into the engine mount, recessed 1/2 inch, and glue into position. Then glue this whole assembly into the booster tube, gas tube forward, so that the rear of the engine tube is recessed 1/4 inch into the body. Fillet and allow to dry.

Assemble a second mount but leave out the gas channel. In its place glue the third AR-2050 2-1/4 inches into the engine tube. Glue this assembly into the other (17-1/2-inch) BT-70 with the engine tube flush with the end of the outer tube.

Now glue the balsa adapter (TA-6070) and nose cone (BNC-60L) into the BT-60s. You may want to hollow the nose cone before you glue it in place since it comprises nearly one tenth of the total weight of the empty rocket.

Cut the eight fins from 1/8 inch balsa stock. Round the leading edges of the upper stage fins and trailing edges of the booster fins and the tips of both. Attach the fins to their respective body tubes, giving extra attention to strong joints.

Since the Grumpy Dog II is too heavy to be launched from anything but a "C" rail, make the launch lugs accordingly. You can use the 1/8th inch balsa standoffs as I did, or the "T" guide, but make them strong. You can put any type of recovery system you want into the Grumpy Dog, and you might want to rig a sling for the BT-60s.

Go lightly with the paint, for the rocket already weighs thirteen ounces.

To set the Dog up for launch, wrap the D12-5 with tape until it fits snugly into the upper stage, protruding 1/2 inch. Do the same with the booster engine. When the upper and lower stages are mated, the upper stage engine fits into the booster engine tube. If you do not fly in a heavy wind, you will find that the Grumpy Dog II has a surprising amount of stability for its size. It's a definite crowd pleaser, and you'll get a real kick out of it. A

fly a DO
GRUMPY G



CAUTION!!
TOTAL WEIGHT WITH ENGINES
MUST NOT EXCEED 1 POUND.

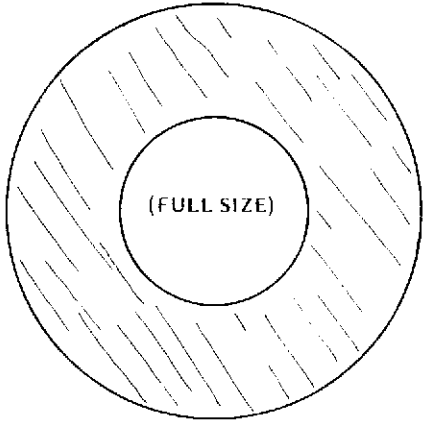
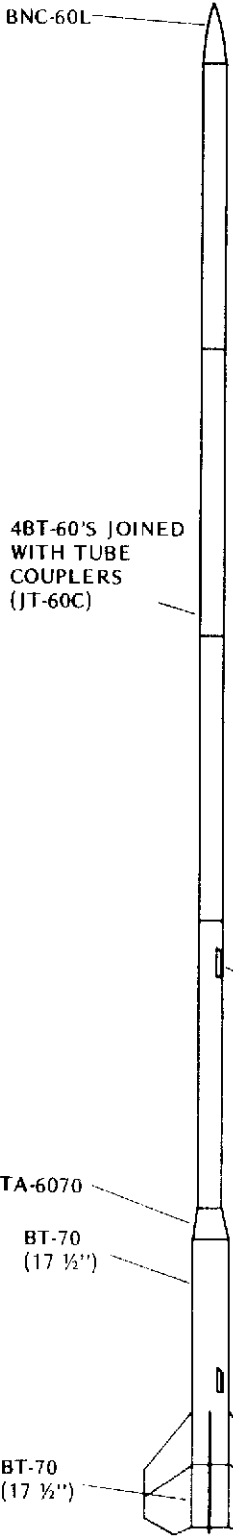

CENTERING RINGS
(MAKE 4 FROM 1/8" BALSA)

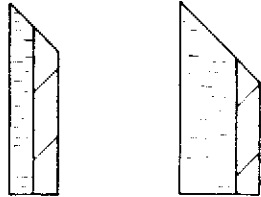

LAUNCH LUGS & STAND OFFS

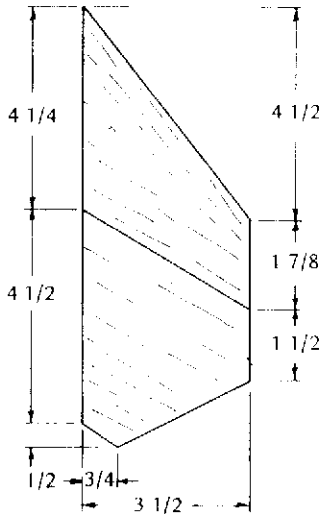

FINS
(MAKE 4 FROM 1/8" BALSA)

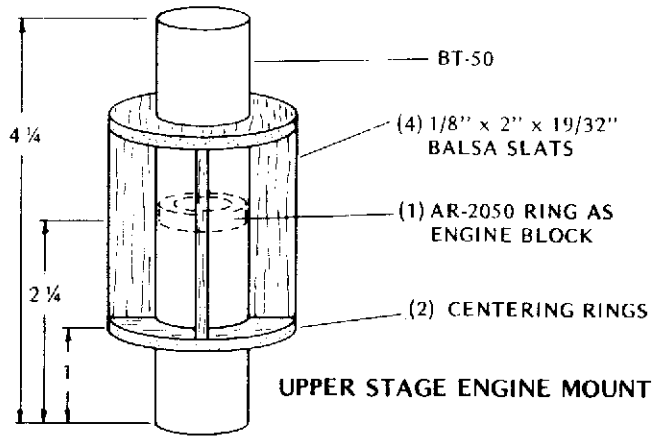

UPPER STAGE ENGINE MOUNT

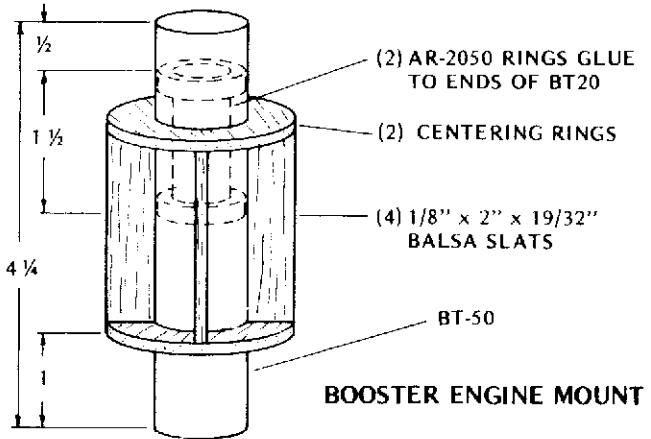

BOOSTER ENGINE MOUNT

RECOMMENDED ENGINES
 BOOSTER - D-12-0
 UPPER STAGE - D-12-3 or 5

the GRUMPY DOG II

BY PAUL ENGELAUF
 DRAWN BY PAUL C. CONNER II

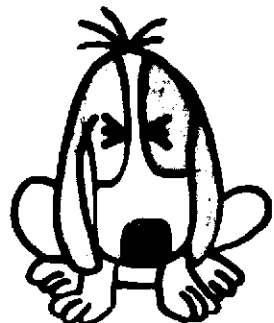



NAR TECHNICAL SERVICES

P. O. BOX 725

NEW PROVIDENCE, NJ 07974