

FRONT VIEW

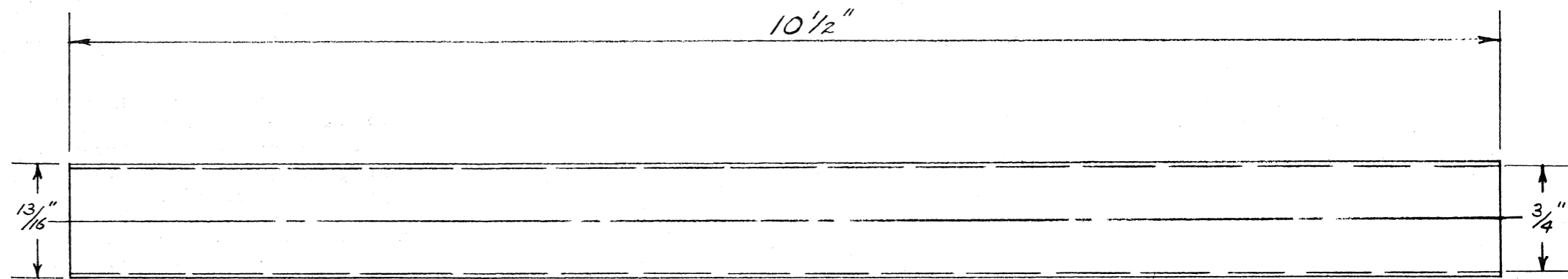

BODY TUBE

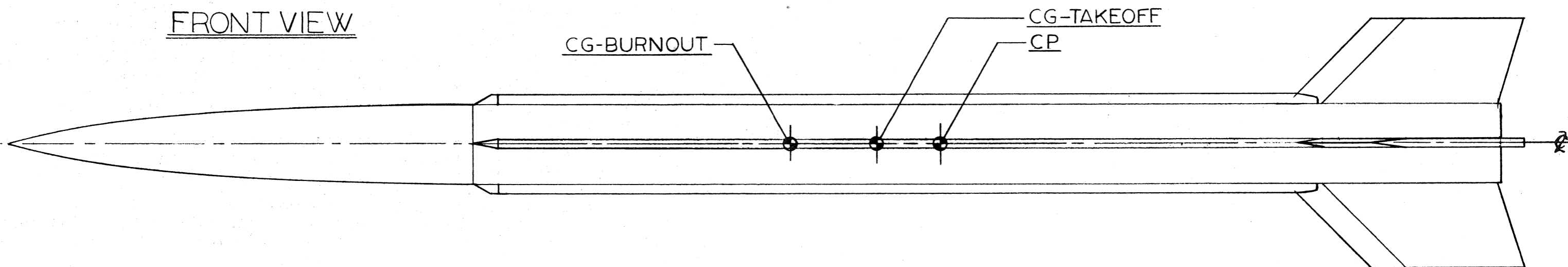

SIDE VIEW

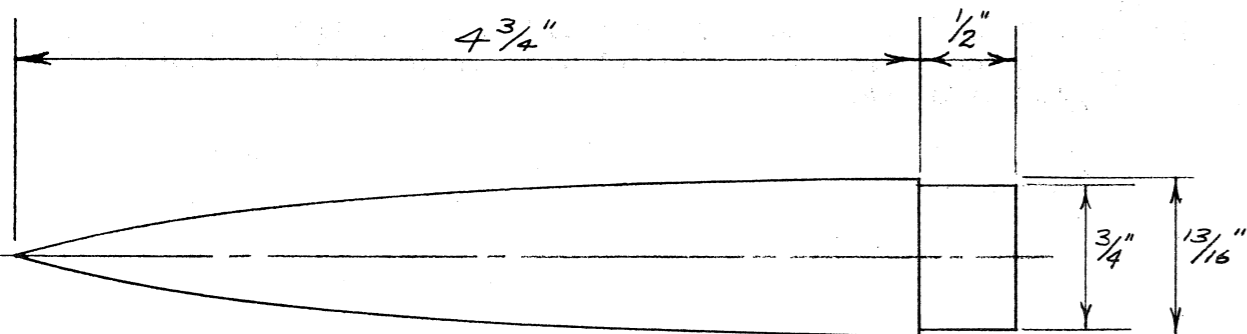

NOSE CONE

WEIGHT (NO MOTOR): 1.4 oz.

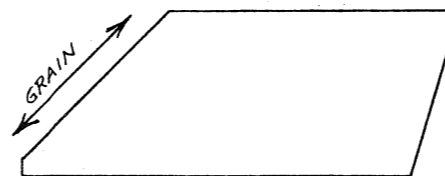

FIN PATTERN

FOR NON COMMERCIAL USE ONLY	
 NATIONAL ASSOCIATION OF ROCKETRY PLAN PROGRAM	
AEROBEE-150A	
MODEL SCALE: 1:18.45	DRAWING SCALE: Full
SCALE SOURCE: Aerojet General Corp.	
DESIGN BY: Stine	DRAWN BY: GHS
CHECKED BY: WSR	RELEASED: 6 Feb. 1961
DRAWING NUMBER: NAR- 109	

National Association of Rocketry

Plan No. 109

PLAN PROGRAM FACT SHEET

Model Name Aerobee-150A

Prototype Data: The Aerobee-150A is made by the Aerojet-General Corporation and is a modified Aerobee-Hi sounding rocket. The modifications include redesign of the fins and use of four fins instead of three. The fins were changed to improve the aerodynamic characteristics and to simplify the manufacturing of the rocket. Other minor changes were made to generally improve the rocket and its performance. The Aerobee-150A is launched from the tower at NASA's Wallops Island range. The rocket is capable of carrying a 180 pound payload to 150 miles. It uses liquid propellants -- red fuming nitric acid and aniline-furfuryl alcohol to achieve a thrust of 4100 pounds. The rocket is 15 inches in diameter and weighs about 1500 pounds at launch. Empty weight without payload is about 270 pounds. This Aerobee rocket is the latest in the Aerobee series. The first Aerobee rocket was flown in 1949.

Model Data: The commercial Aerobee-Hi kit may be modified to make an Aerobee-150A, but it will not be exact scale. The drawings were accurately scaled from plans supplied by the Aerojet-General Corporation.

Standard model rocket construction techniques and materials, such as described in NAR Technical Report #9 and others, are used throughout. The nose cone is turned from hardwood. The body tube is a thin-walled paper tube with 3/4" i.d., 13/16" o.d., and 10 ~~1~~ 1/2" long. Commercially-available tubes may be cut to length with a razor saw. The fins are cut from 3/32" balsa. The body shrouds are made from 3/32" square balsa and rounded to shape.

The model was designed for tower launching, but may be modified for rod launching by glueing a launching lug on the side of the body tube.

The model was designed to use NAR Type A, B, or C engines. For best flight results, observe the take-off CG point.

The model Aerobee-150A is a beautiful model in flight and performs well. In fact, the performance is considerably more stable than the Aerobee-Hi model because of the improved fin design and the additional fin area.

Install the recovery system of your choice, and always fly in open areas away from trees and power lines. Always use a launcher at least 36" long.

For additional information on construction, materials, techniques, and flight, refer to the various NAR Technical Reports on the subject of your interest.