

# maxi Alpha

## FLYING MODEL ROCKET

SKILL LEVEL 2

1. Beginner 2. Intermediate 3. Challenge  
4. Advanced 5. Expert

Great scale version of our most popular rocket, the Alpha. Great for demonstrations with slow realistic lift-off and dramatic 24" parachute recovery. Flights up to 500 feet with T61 engine. Comes with die-cut latex fins, molded plastic nose cone, nose, quick-release engine mount and huge decals. Assembles in approximately 30 minutes. Perfect launch vehicle for one, two, or three Firefly Gliders. (Not included.)



This is a hobby kit requiring assembly. Recommended for ages 10 to adult. Engines, launch systems, glue and finishing supplies are not included. Adult supervision is suggested for those under 10 years of age when using model rockets.

**Nearly  
3 Feet Tall!**

#### Specifications:

Length: 29.25"  
Diameter: 2.4" (at widest)  
Weight: 3.17 lb.

#### Recommended Engine:

T61



A DIVISION OF DUNN  
ESTES INDUSTRIES  
MICHIGAN, U.S.A. 48806



# maxi Alpha

KIT NO. 1291

Skill Level 2

This kit recommended for intermediate skilled rocketeers.

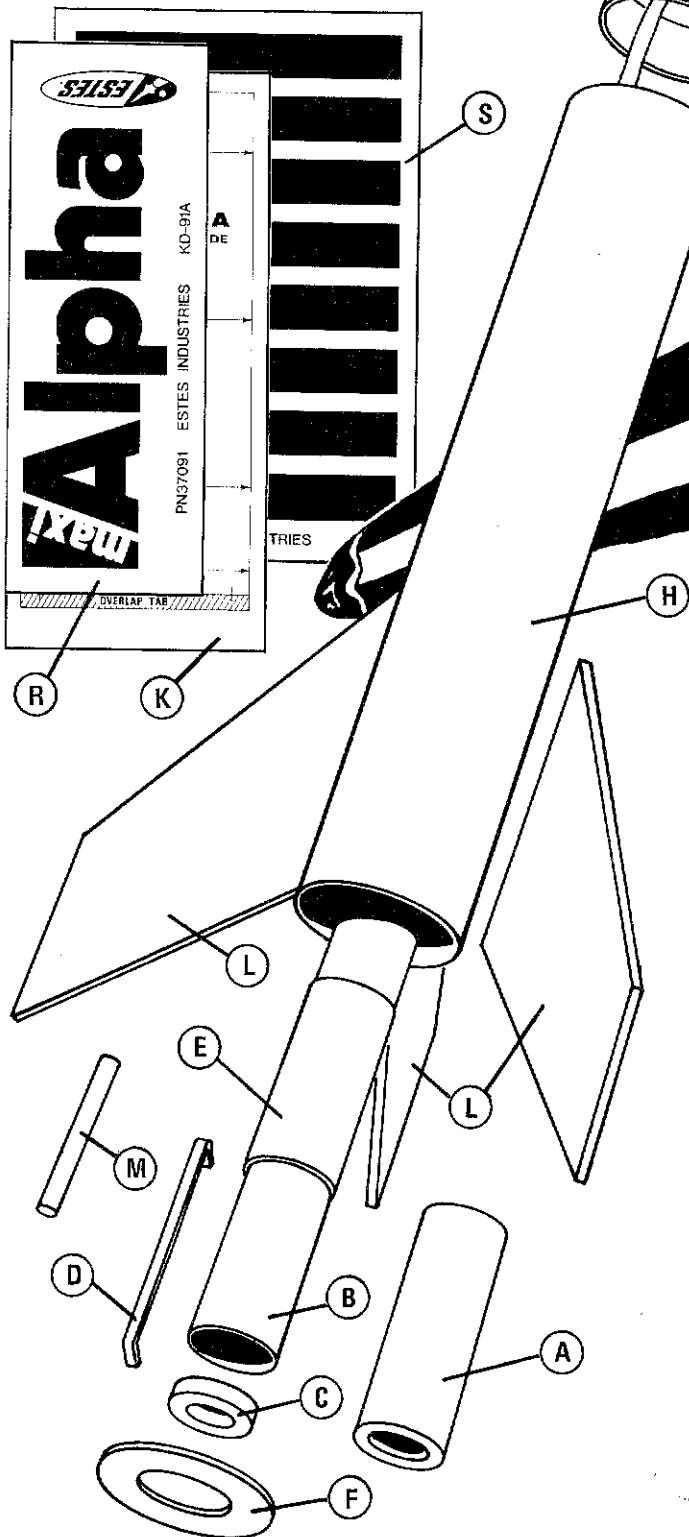

## PARTS LIST

		PART NO.
A)	1	Dummy Engine Casing (type EC-6) . . . . . 35012
B)	1	Engine Mount Tube (type BT-50L) 12.75" long . . 30366
C)	1	Engine Block (type AR-2050) . . . . . 30164
D)	1	Engine Hook (type EH-2) . . . . . 35025
E)	1	Retainer Tube (type BT-52S) 4.0" long . . . . . 30380
F)	2	Centering Rings (type TA-69) . . . . . 30052
G)	1	Shock Cord (type SC-2MJ) . . . . . 85738
H)	1	Main Body Tube (type BT-80KD) 14.2" long . . . . 30433
I)	1	Tube Coupler (type JT-80C) . . . . . 30274
J)	1	Forward Body Tube (type BT-80) 7.6" long . . . . 30432
K)	1	Pattern Sheet (type SP-91) . . . . . 83233
L)	3	Die-Cut Balsa Sheet (type BF-91) . . . . . 32295
M)	1	Launch Lug (type LL-3B) . . . . . 38166
N)	1	Parachute (type PK-24A) . . . . . 85568
O)	1	Shroud Line (type SLT-144) 144.0" long . . . . . 38241
P)	6	Tape Discs (type TD-3F) . . . . . 38406
Q)	1	Nose Cone (type PNC-80K) . . . . . 71035
R)	1	Decal (type KD-91A) . . . . . 37091
S)	1	Decal (type KD-91B) . . . . . 37092

In addition to the parts included in this kit you will need scissors, a pencil, a ruler, white glue, a sharp model knife (or single edge razor blade), sandpaper, masking tape, sanding sealer, and paint.

## IMPORTANT:

Read all instructions before beginning work on your model. Make sure you have all parts and materials. When you are thoroughly familiar with the assembly procedure, begin construction. Check off each step as you complete it. In each step, test-fit the parts together before applying any glue. If some part doesn't fit properly, sand lightly or build up as appropriate for precision assembly.



A SUBSIDIARY OF DAMON

ESTES INDUSTRIES  
PENROSE, COLO. 81240

# ASSEMBLY INSTRUCTIONS

## (A) SMEAR GLUE INSIDE TUBE

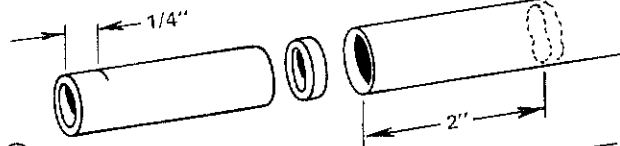

## (B) PUSH ENGINE BLOCK INTO TUBE WITH CASING

## (C) WITHDRAW CASING IMMEDIATELY

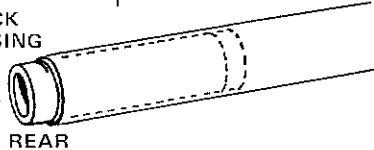

**1** Mark the dummy engine casing (part A) 1/4" from one end. Use your finger or a stick to smear a band of glue inside the engine mount/stuffer tube (part B) about 2" from one end. Insert the engine block (part C) into same end of the engine mount/stuffer tube. Use the engine casing to push the engine block into place (with mark on casing even with end of tube) with one smooth movement. Remove the casing immediately.

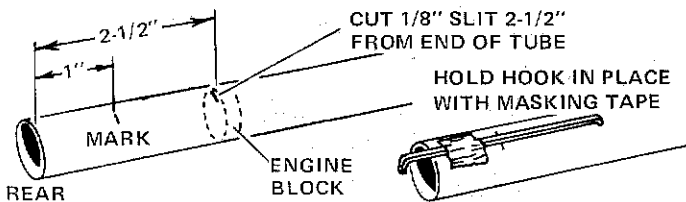

**2** Cut a 1/8" slit in the stuffer tube, 2-1/2" from the engine block end. The slit will be even with the edge of the engine block. Mark the stuffer tube 1" from the engine block end. Temporarily tape the engine hook (part D) in place.

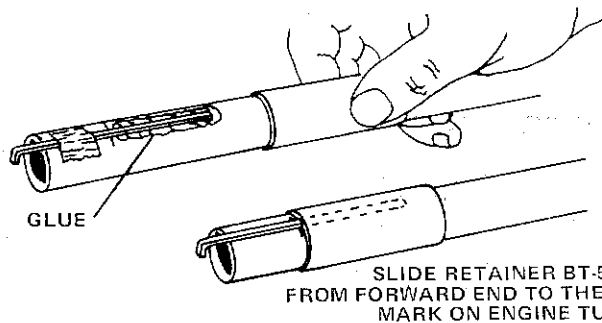

**3** Apply a heavy line of glue on the engine hook from the 1" mark forward to the point where the engine hook enters the stuffer tube. Slip the engine hook retainer tube (part E) onto the forward end of the stuffer tube and slide it back over the engine hook to the 1" mark. Wipe away any excess glue and remove the tape from the engine hook.

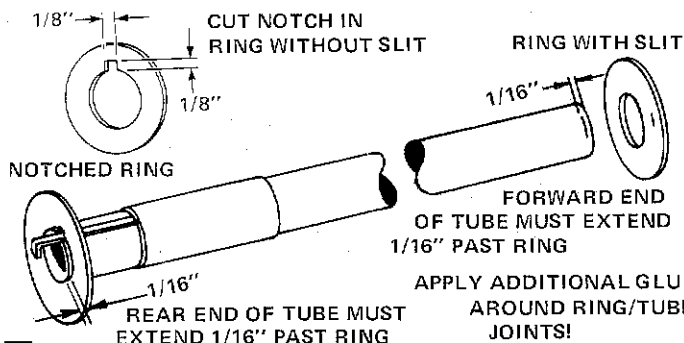

**4** Remove the centering rings from the ring set (part F). Cut a 1/8" wide, 1/8" long notch in the ring without the slit. Place the rings on the stuffer tube as shown. The stuffer tube should project 1/16" past the centering rings at each end. Glue centering rings securely in place and allow to dry. Apply a second layer of glue to both sides of each ring for strength.

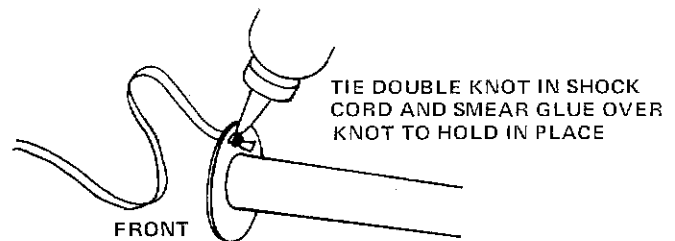

**5** Tie a secure double knot at one end of the shock cord (part G). Slip unknotted end through the slit in the forward centering ring. Pull the knot tightly against the back of the ring as shown. Apply a heavy coating of glue over the knot to hold it in place.

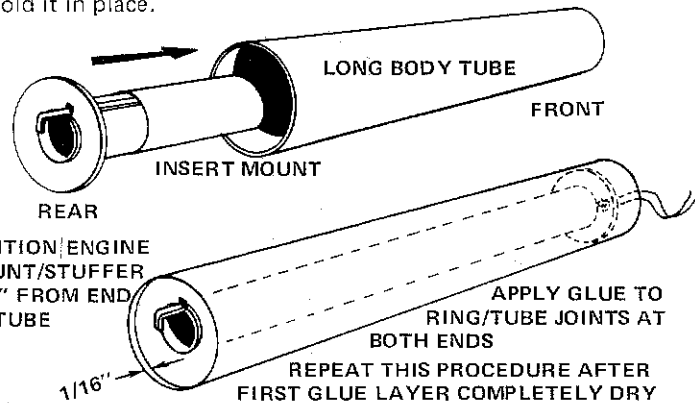

**6** When the glue on the engine mount/stuffer tube assembly is completely dry, place it inside the 14.2" long main body tube (part H) as shown. The centering ring at the engine hook end of the assembly should be placed 1/16" inside the tube. Apply glue to the ring/tube joints at both ends. After these joints are fully dry, apply a second coat of glue to the ring/tube joints. These joints must be completely sealed to prevent loss of ejection gasses.

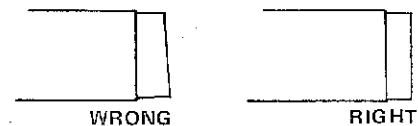
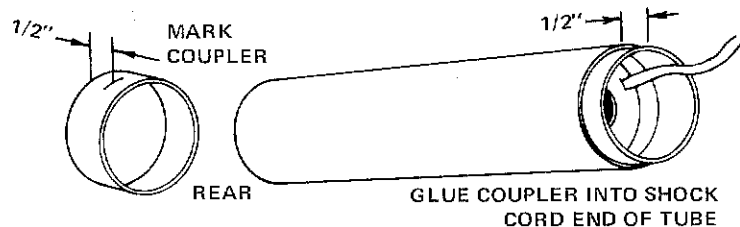

**7** Mark the tube coupler (part I), 1/2" from one edge. Smear a band of glue inside the main body tube about 1/4" in from the shock cord end. Insert the tube coupler and push until the mark is even with the end of the tube. Be sure the tube coupler is installed squarely as shown.

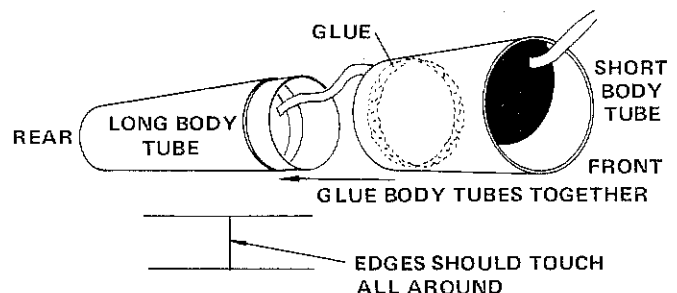

**8** Smear a band of glue around the inside of one end of the forward body tube (part J), about 1/4" from the end. Slide this end of the tube over the tube coupler attached to the main

body tube in one smooth movement. The edges of the two body tubes should touch all around. The alignment should be perfectly straight.

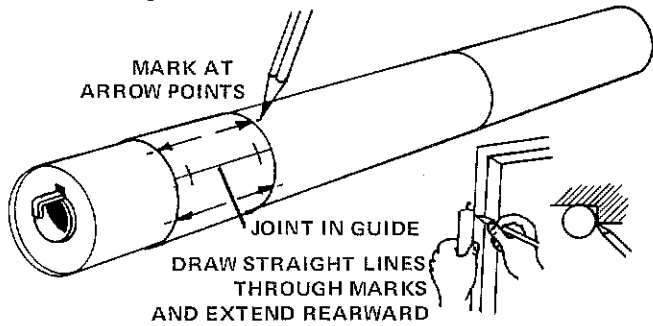

**9** Cut out the tube marking guide from the pattern sheet (part K). Wrap it around the rear of the body. Mark the tube at each arrow point, front and rear. Draw a straight line connecting each matching front and rear mark. (Use a ruler when drawing lines.) Extend the launch lug line forward 14".

**SAND BOTH SIDES OF DIE-CUT SHEET SMOOTH WITH FINE SANDPAPER**

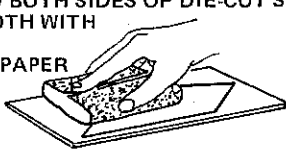

**CAREFULLY REMOVE THE FINS FROM THE SHEET**

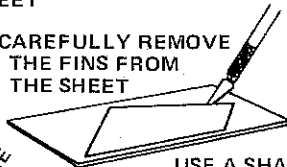

**USE A SHARP KNIFE TO FREE THE EDGES**

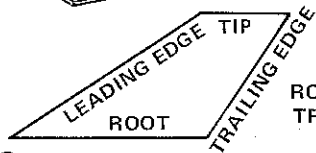

**ROUND LEADING EDGE, TRAILING EDGE, AND TIP.**

**10** Fine sand the die-cut balsa sheets (part L), then carefully remove the fins from the sheets. Free the edges with a sharp knife. Sand the leading, trailing, and tip edges of the fins round. Leave the root edges square.

**RUB A LINE OF GLUE INTO ROOT EDGE OF EACH FIN**

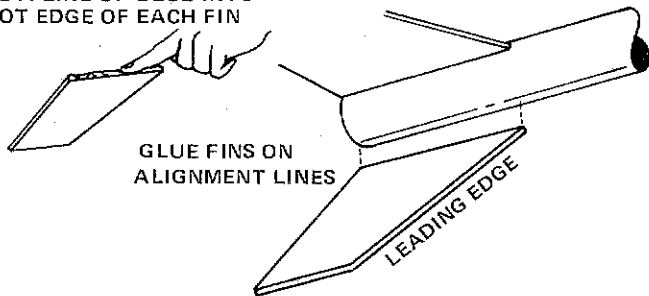

**11** Rub a line of glue into the root edge of each fin and allow to dry. Glue the fins to the body tube on the fin alignment lines drawn in step 9. Refer to the illustration to be sure you position the fins correctly. Adjust the fins so they project straight away from the body tube. Do not set the rocket on its fins while the glue is wet.

**CUT LAUNCH LUG INTO TWO 1" LENGTHS**

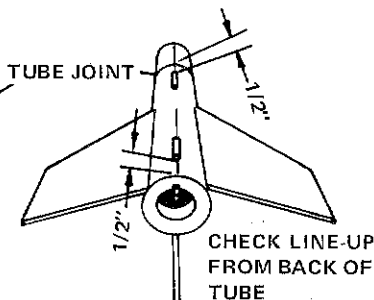

**12** Cut the launch lug (part M) into two 1" lengths. Glue one of these lugs on the launch lug alignment line 1/2" from the rear of the rocket. Glue the remaining lug piece on the launch lug alignment line 1/2" rearward from the joint where the two body tubes meet. Align the launch lugs straight on the body tube.

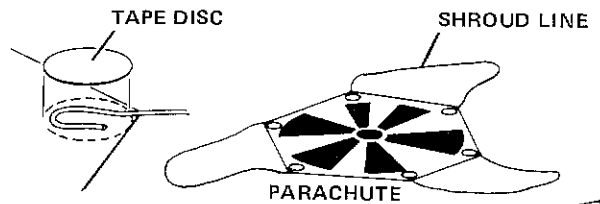

**PASS PARACHUTE THROUGH LOOP**

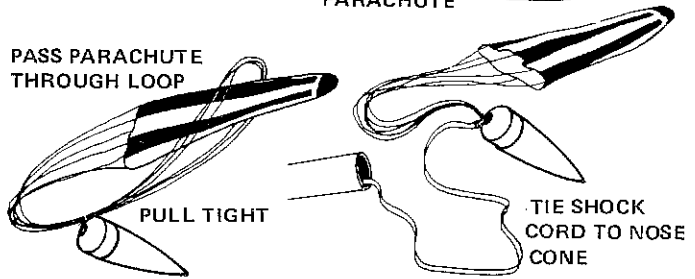

**13** Cut out the parachute (part N) on its edge lines. Cut three 48" lengths of shroud line (part O). Attach the line ends to the top of the parachute with tape discs (part P) as shown. Pass the shroud line loops through the ring on the nose cone (part Q). Pass the parachute through the loop ends and draw the lines tight against the ring. Set the knot with a drop of glue. Tie the free end of the shock cord to the nose cone.

**FILLETS SHOWN ARE SLIGHTLY EXAGGERATED**

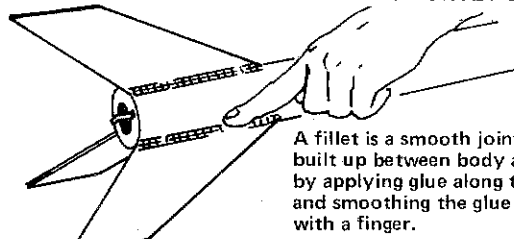

A fillet is a smooth joint built up between body and fin by applying glue along the joint and smoothing the glue with a finger.

**14** Reinforce the fin joints with glue. Holding the rocket horizontally (level), apply a line of glue to both sides of each joint. Smooth out the glue with your finger. Keep the rocket level until the glue dries.

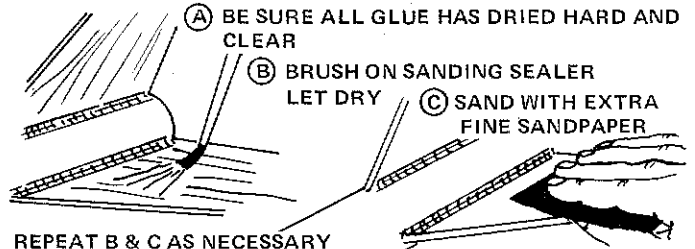

**REPEAT B & C AS NECESSARY**

**TO COMPLETELY FILL PORES IN WOOD**

**15** When all glue on the outside of the model is dry, prepare the balsa parts for painting. Apply at least two coats of sanding sealer to the fins. Let dry and sand lightly between coats. Do this until the tiny holes in the wood are filled and everything looks and feels smooth.

**SPRAY PAINT FOR BEST RESULTS.**

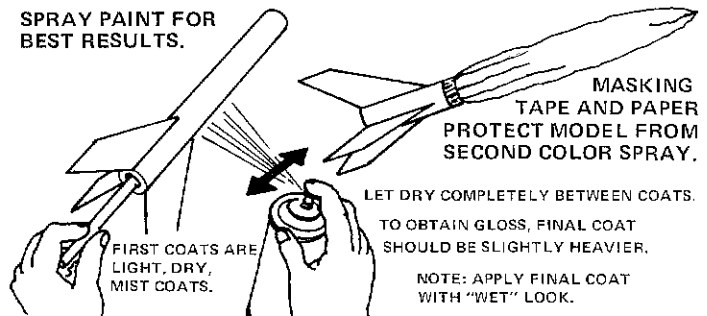

**HOLD CAN STRAIGHT AND SPRAY IN LONG, SMOOTH "STROKES". SHAKE CAN PERIODICALLY.**

**16** After the sanding sealer is completely dry, paint the entire model white. Let the white dry overnight. Apply masking tape and paper to cover and protect the areas which will remain

white. (See the Decor Layout illustration.) Paint the fins and the rear 5-1/2" of the body tube red. Carefully remove the masking tape and paper as soon as the paint is dry.

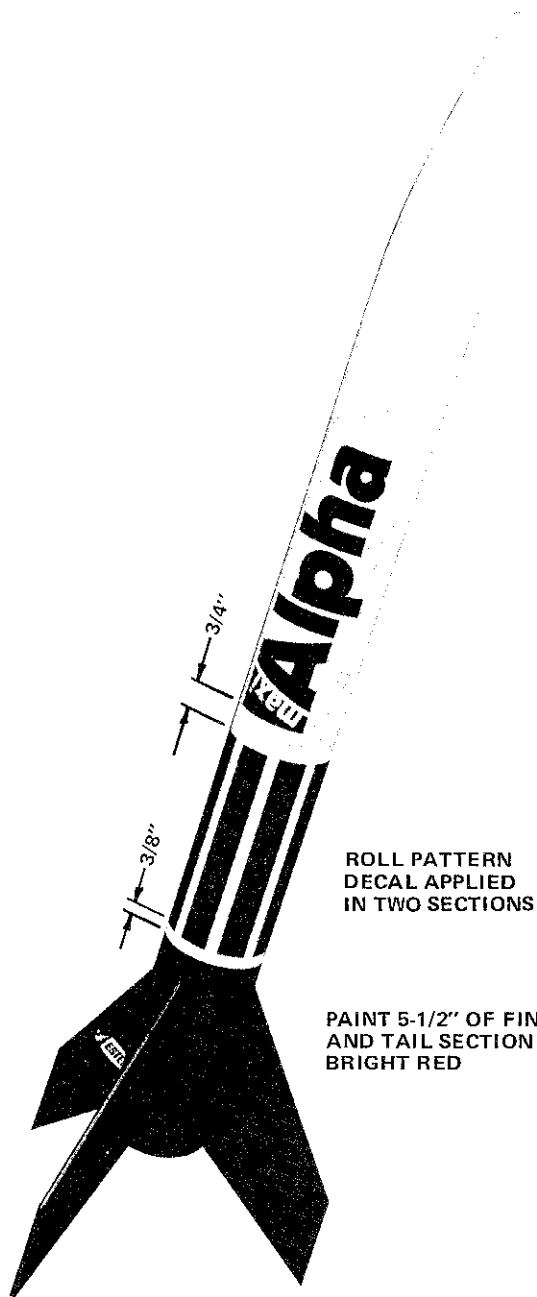

**17** When all the paint is dry, apply decals (part R & S). To apply the water transfer decals, cut out an individual section of the decal and dip in lukewarm water for about 10 seconds. When the decal slides freely on the backing paper, slip it from the backing sheet onto the model.

## LAUNCHING COMPONENTS

To launch your rocket you will need the following items:

- An Estes model rocket launching system fitted with a heavy-duty launch rod (Estes Cat. No. 2239).
- Parachute recovery wadding (Estes Cat. No. 2274).
- Estes D12-5 model rocket engines. (Estes Cat. No. 1667)

Be sure to follow the \*HIAA-NAR Model Rocketry Safety Code when carrying out your model rocketry activities.

\*HIAA-NAR — Hobby Industry Association of America  
National Association of Rocketry

## COUNTDOWN CHECKLIST

**T-13** Pack 12 to 14 squares of loosely crumpled Estes Recovery Wadding into main body tube. The wadding should fill the bottom of the parachute compartment for at least two inches.

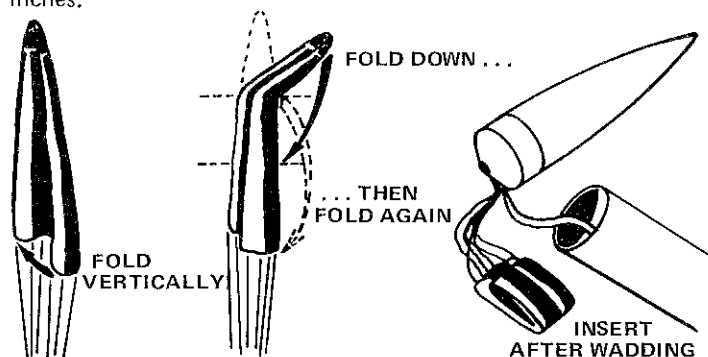

**T-12** Loosely fold the parachute. Lay it on top of the wadding, with its shroud lines and shock cord on top of it. Slide the nose cone into place.

NOTE: DO NOT pack parachute until you are actually ready to launch. For maximum parachute reliability, lightly dust the parachute with ordinary talcum powder before each flight, especially in cold weather.

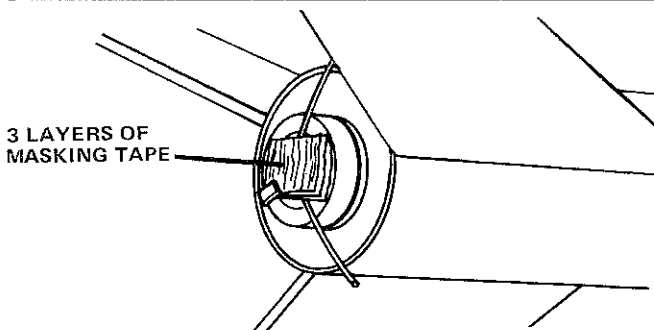

**T-11** Install an igniter in a D12-5 engine as directed in the engine instructions. Insert engine into the engine mount. Make sure the engine hook latches securely over the end of the engine.

**T-10** Disarm the launch panel--remove safety key.

**T-9** Lower the rocket into position on the launch rod. (A 3/16" diameter launch rod is recommended.) Clean the micro-clips and attach one to each lead of the igniter. The clips must not touch each other, and the igniter leads must not cross.

**T-8** Clear the launch area, alert recovery crew and trackers.

**T-7** Check for low flying aircraft and unauthorized persons in recovery area.

**T-6** Arm the launch panel--insert safety key.

**-5 - 4 - 3 - 2 - 1 LAUNCH!!**

## MISFIRE PROCEDURE

Occasionally the igniter will heat and burn into two pieces without igniting the engine. This is almost always caused by a failure to install it correctly. Disarm the launch panel, remove the model, clean the igniter residue from the nozzle, and install a new igniter. Follow the launching procedure again.

Estes Maxi Alpha  
Kit #1291  
Fins: 3 x 1/8" Hard Balsa

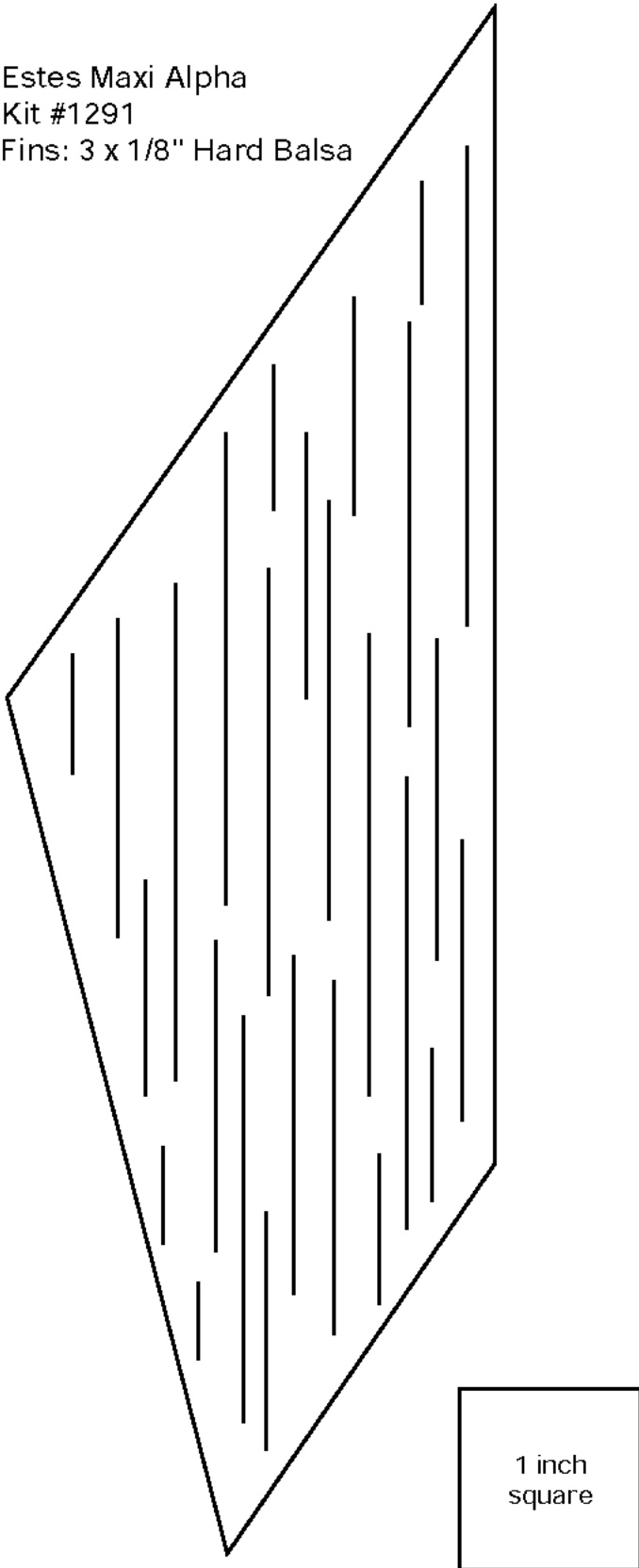

Re-drawn by Greg K. Poehlein

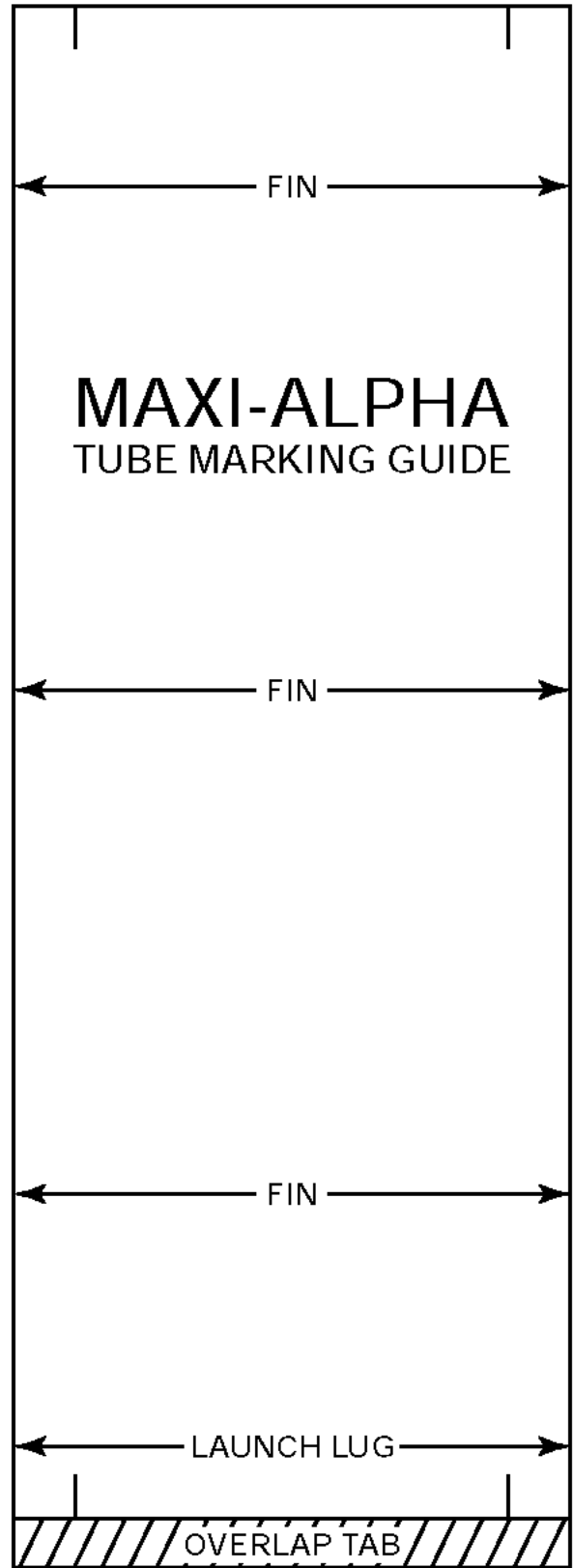

ESTES INDUSTRIES  
SP-91 PN 83233

**maxi**  
**RA**  
**PRO**  
**RES**



PN37091 ESTES INDUSTRIES KD-91A

[REDACTED]

[REDACTED]

[REDACTED]

[REDACTED]

[REDACTED]

[REDACTED]

[REDACTED]

[REDACTED]